

HITACHI

KAOHSIUNG HITACHI ELECTRONICS CO., LTD.

FOR MESSRS: _____

DATE: Oct. 1st 2010

CUSTOMER'S ACCEPTANCE SPECIFICATIONS

TX18D35VM0AAB

Contents

No.	ITEM	SHEET No.	PAGE
1	COVER	7B64PS 2701-TX18D35VM0AAB-1	1-1/1
2	RECORD OF REVISION	7B64PS 2702-TX18D35VM0AAB-1	2-1/1
3	GENERAL DATA	7B64PS 2703-TX18D35VM0AAB-1	3-1/1
4	ABSOLUTE MAXIMUM RATINGS	7B64PS 2704-TX18D35VM0AAB-1	4-1/1
5	ELECTRICAL CHARACTERISTICS	7B64PS 2705-TX18D35VM0AAB-1	5-1/1
6	OPTICAL CHARACTERISTICS	7B64PS 2706-TX18D35VM0AAB-1	6-1/2~2/2
7	BLOCK DIAGRAM	7B64PS 2707-TX18D35VM0AAB-1	7-1/1
8	RELIABILITY TESTS	7B64PS 2708-TX18D35VM0AAB-1	8-1/1
9	LCD INTERFACE	7B64PS 2709-TX18D35VM0AAB-1	9-1/6~6/6
10	OUTLINE DIMENSIONS	7B63PS 2710-TX18D35VM0AAB-1	10-1/2~2/2
11	APPEARANCE STANDARD	7B64PS 2711-TX18D35VM0AAB-1	11-1/3~3/3
12	PRECAUTIONS	7B64PS 2712-TX18D35VM0AAB-1	12-1/2~2/2
13	DESIGNATION OF LOT MARK	7B64PS 2713-TX18D35VM0AAB-1	13-1/1~1/1

ACCEPTED BY: _____

PROPOSED BY: Ken Chen

2. RECORD OF REVISION

DATE	SHEET No.	SUMMARY

3. GENERAL DATA

3.1 DISPLAY FEATURES

This module is a 7" WVGA of 16:9 format amorphous silicon TFT. The pixel format is vertical stripe and sub pixels are arranged as R (red), G (green), B (blue) sequentially. This display is RoHS compliant, COG (chip on glass) technology and LED backlight are applied on this display.

Part Name	TX18D35VM0AAB
Module Dimensions	165.0(W) mm x 104.0(H) mm x 12.8 (D) mm typ.
LCD Active Area	152.4(W) mm x 91.44(H) mm
Pixel Pitch	0.1905(W) mm x 0.1905 (H) mm
Resolution	800 x 3(RGB)(W) x 480(H) dots
Color Pixel Arrangement	R, G, B Vertical stripe
LCD Type	Transmissive Color TFT; Normally Black
Display Type	Active Matrix
Number of Colors	262k Colors
Backlight	18 LEDs (3 series x 6)
Weight	280 typ. (g)
Interface	C-MOS; 6-bit RGB; 40 pins
Power Supply Voltage	3.3V for LCD; 12V for Backlight
Power Consumption	1.55W for LCD; 6W for Backlight
Viewing Direction	Super Wide Version (In-Plane Switching)

4. ABSOLUTE MAXIMUM RATINGS

Item	Symbol	Min.	Max.	Unit	Remarks
Supply Voltage	VDD	-0.3	3.6	V	-
Input Voltage of Logic	VI	-0.3	VDD+0.3	V	Note 1
Operating Temperature	Top	-30	80	°C	Note 2
Storage Temperature	Tst	-40	90	°C	Note 2
Backlight Input Voltage	VLED	-	15	V	-

Note 1: The rating is defined for the signal voltages of the interface such as DCLK, DTMG, and RGB data bus.

Note 2: The maximum rating is defined as above based on the temperature on the panel surface, which might be different from ambient temperature after assembling the panel into the application. Moreover, some temperature-related phenomenon as below needed to be noticed:

- Background color, contrast and response time would be different in temperatures other than 25°C.
- Operating under high temperature will shorten LED lifetime.

5. ELECTRICAL CHARACTERISTICS

5.1 LCD CHARACTERISTICS

$T_a = 25\text{ }^\circ\text{C}$, $V_{SS} = 0\text{V}$

Item	Symbol	Condition	Min.	Typ.	Max.	Unit	Remarks
Power Supply Voltage	VDD	-	3.0	3.3	3.6	V	-
Input Voltage of Logic	VI	"H" level	0.7VDD	-	VDD+0.3	V	Note 1
		"L" level	-0.3	-	0.25VDD		
Power Supply Current	IDD	VDD=3.3V	440	470	500	mA	Note 2
Vsync Frequency	f_v	-	47	60	75	Hz	-
Hsync Frequency	f_H	-	16.7	31.5	41.7	KHz	-
CLK Frequency	f_{CLK}	-	30.0	33.0	36.0	MHz	-

Note 1: The rating is defined for the signal voltages of the interface such as DTMG, DCLK and RGB data bus.

Note 2: An all white check pattern is used when measuring IDD. f_v is set to 60 Hz.

Note 3: 1.0A fuse is applied in the module for IDD. For display activation and protection purpose, power supply is recommended larger than 2.5A to start the display and break fuse once any short circuit occurred.

5.2 BACKLIGHT CHARACTERISTICS

$T_a = 25\text{ }^\circ\text{C}$

Item	Symbol	Condition	Min.	Typ.	Max.	Unit	Remarks
LED Input Voltage	VLED	-	11.7	12	12.3	V	Note1
LED Forward Current (Dim Control)	ILED	0V; 0% duty	490	500	510	mA	Note 2
		3.3VDC; 100% duty	34	40	46		
LED lifetime	-	500 mA	-	70K	-	hrs	Note 3

Note 1: As Fig. 5.1 shown, LED current is constant, 500 mA, controlled by the LED driver when applying 12V VLED.

Note 2: Dimming function can be obtained by applying DC voltage or PWM signal from the display interface CN1. The recommended PWM signal is 1K ~ 10K Hz with 3.3V amplitude.

Note 3: The estimated lifetime is specified as the time to reduce 50% brightness by applying 500 mA at $25\text{ }^\circ\text{C}$.

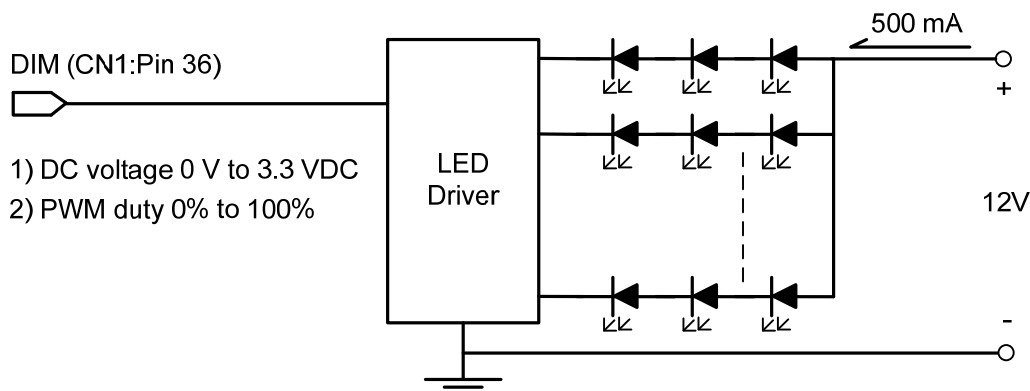

Fig 5.1

6. OPTICAL CHARACTERISTICS

The optical characteristics are measured based on the conditions as below:

- Supplying the signals and voltages defined in the section of electrical characteristics.
- The backlight unit needs to be turned on for 15 minutes.
- The ambient temperature is 25 °C .
- In the dark room around 500~1000 lx, the equipment has been set for the measurements as shown in Fig 6.1.

$$T_a = 25\text{ }^{\circ}\text{C}, f_v = 60\text{ Hz}, V_{DD} = 3.3\text{V}$$

Item	Symbol	Condition	Min.	Typ.	Max.	Unit	Remarks	
Brightness of White	-	$\phi = 0^{\circ}, \theta = 0^{\circ}$,	640	800	-	cd/m ²	Note 1	
Brightness Uniformity	-	ILED= 80	70	-	-	%	Note 2	
Contrast Ratio	CR	mA/series	-	600	-	-	Note 3	
Response Time (Rising + Falling)	$T_r + T_f$	$\phi = 0^{\circ}, \theta = 0^{\circ}$	-	-	45	ms	Note 4	
Viewing Angle	θ_x	$\phi = 0^{\circ}, CR \geq 10$	-	85	-	Degree	Note 5	
	$\theta_{x'}$	$\phi = 180^{\circ}, CR \geq 10$	-	85	-			
	θ_y	$\phi = 90^{\circ}, CR \geq 10$	-	85	-			
	$\theta_{y'}$	$\phi = 270^{\circ}, CR \geq 10$	-	85	-			
Color Chromaticity	Red	X	$\phi = 0^{\circ}, \theta = 0^{\circ}$	0.55	0.60	0.65	-	Note 6
		Y		0.31	0.36	0.41		
	Green	X		0.31	0.36	0.41		
		Y		0.54	0.59	0.64		
	Blue	X		0.10	0.15	0.20		
		Y		0.07	0.12	0.17		
	White	X		0.27	0.32	0.37		
		Y		0.29	0.34	0.39		

Note 1: The brightness is measured from the panel center point, P5 in Fig. 6.2, for the typical value.

Note 2: The brightness uniformity is calculated by the equation as below:

$$\text{Brightness uniformity} = \frac{\text{Min. Brightness}}{\text{Max. Brightness}} \times 100\%$$

, which is based on the brightness values of the 9 points measured by BM-5 as shown in Fig. 6.2.

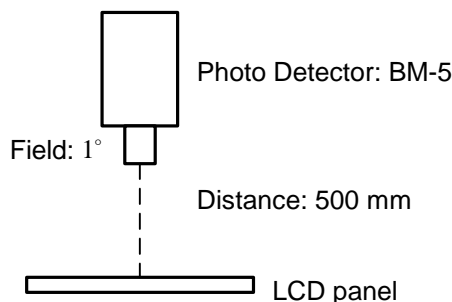

Fig. 6.1

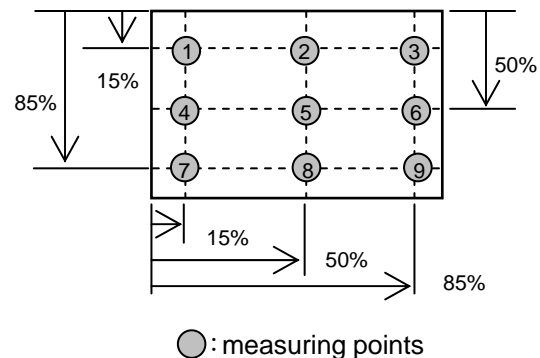
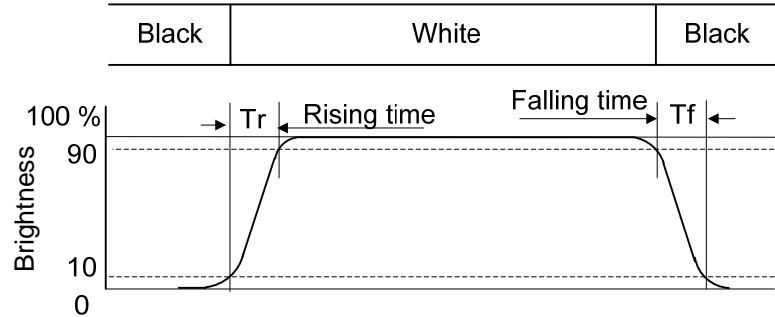

Fig. 6.2

Note 3: The Contrast Ratio is measured from the center point of the panel, P5, and defined as the following equation:

$$CR = \frac{\text{Brightness of White}}{\text{Brightness of Black}}$$

Note 4: The definition of response time is shown in Fig. 6.3. The rising time is the period from 10% brightness to 90% brightness when the data is from black to white. Oppositely, Falling time is the period from 90% brightness falling to 10% brightness.



Note 5: The definition of viewing angle is shown in Fig. 6.4. Angle ϕ is used to represent viewing directions, for instance, $\phi = 270^\circ$ means 6 o'clock, and $\phi = 0^\circ$ means 3 o'clock. Moreover, angle θ is used to represent viewing angles from axis Z toward plane XY.

The display is super wide viewing angle version, so that the best optical performance can be obtained from every viewing direction.

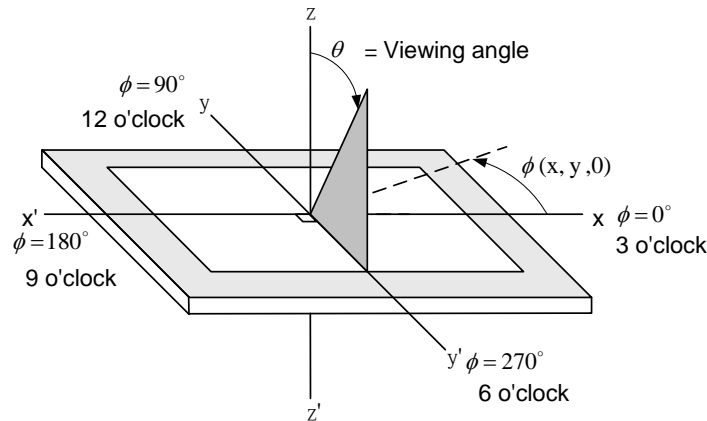
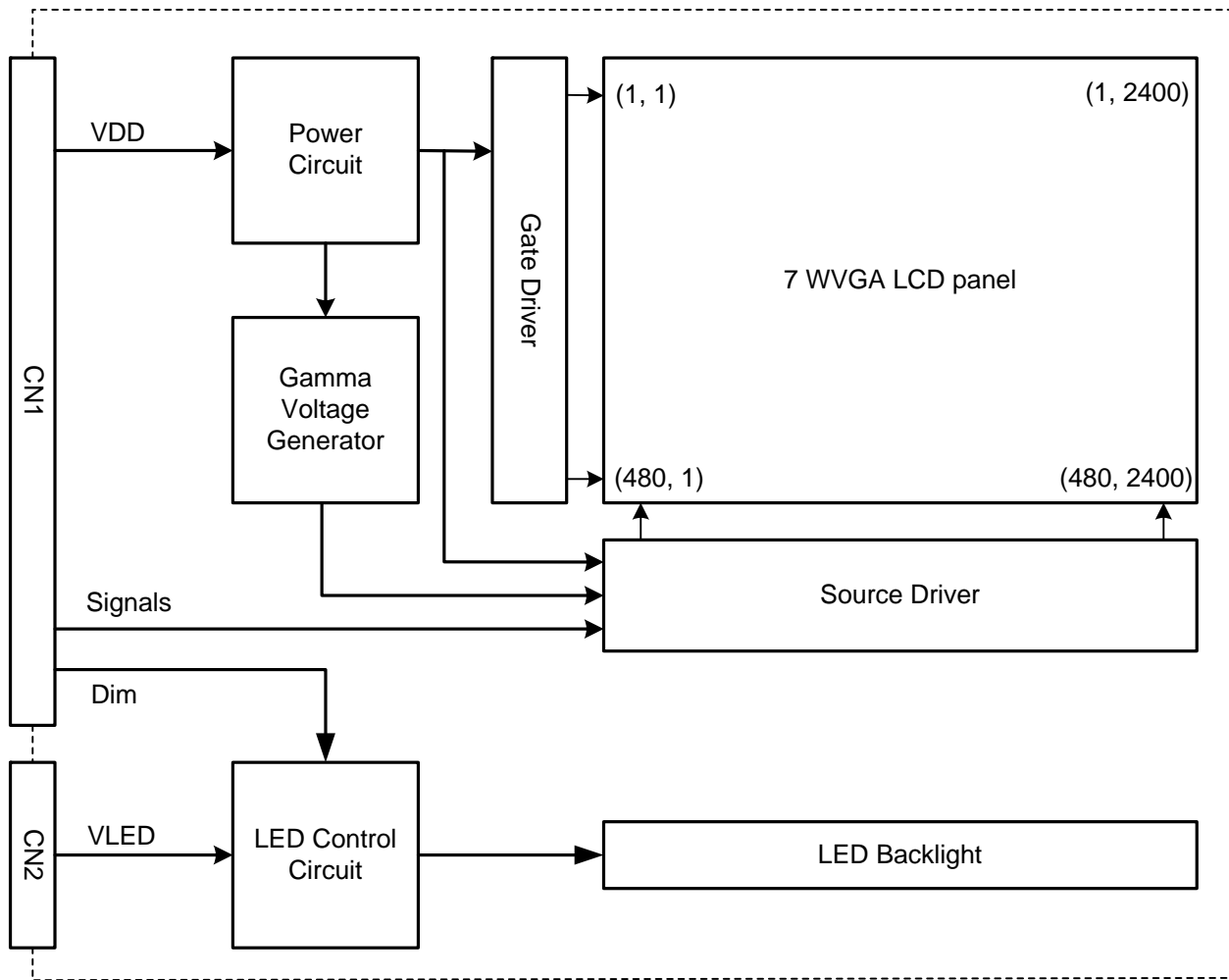

Fig 6.4

Note 6: The color chromaticity is measured from the center point of the panel, P5, as shown in Fig. 6.2.

7 BLOCK DIAGRAM



Note1: Signals are DCLK, DTMG, and RGB data bus.

8. RELIABILITY TESTS

Test Item	Condition	
High Temperature	1) Operating 2) 70 °C	240 hrs
Low Temperature	1) Operating 2) -20 °C	240 hrs
High Temperature	1) Storage 2) 80 °C	240 hrs
Low Temperature	1) Storage 2) -30 °C	240 hrs
Heat Cycle	1) Operating 2) -20 °C ↔ 70 °C 3) 1hrs~2hr~1hrs	200 cycles
Thermal Shock	1) Non-Operating 2) -35 °C ↔ 85 °C 3) 0.5 hr ↔ 0.5 hr	240 hrs
High Temperature & Humidity	1) Operating 2) 40 °C & 85%RH 3) Without condensation 4) Note 4	240 hrs
Vibration	1) Non-Operating 2) 10~150 Hz 3) 3G 4) X, Y, and Z directions	once for each direction
Mechanical Shock	1) Non-Operating 2) 10 ms 3) 50G 4) ±X, ±Y and ±Z directions	Once for each direction
ESD	1) Operating 2) Tip: 200 pF, 250 Ω 3) Air discharge for glass: ± 8KV 4) Contact discharge for metal frame: ± 8KV	1) Glass: 9 points 2) Metal frame: 8 points

Note 1: Display functionalities are inspected under the conditions defined in the specification after the reliability tests.

Note 2: The display is not guaranteed for use in corrosive gas environments.

Note 3: All pins of LCD interface(CN1) have been tested by ± 100V contact discharge of ESD under non-operating condition.

Note 4: Under the condition of high temperature & humidity, if the temperature is higher than 40°C, the humidity needs to be reduced as Fig. 8.1 shown.

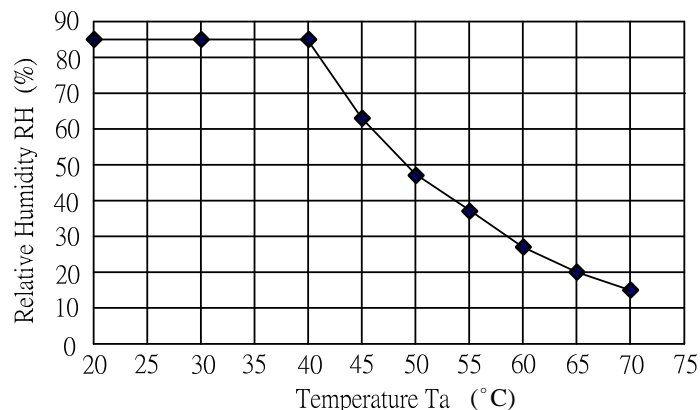

Fig. 8.1

9. LCD INTERFACE

9.1 INTERFACE PIN CONNECTIONS

The display interface connector (CN1) is FA5S040HP1R3000(JAE), and Pin assignment is as below:

Pin No.	Symbol	Signal
1	VDD	Power Supply for Logic
2	VDD	
3	L/R	L/R scan direction (Low: normal, High: Reverse)
4	U/D	U/D scan direction (Low: normal, High: Reverse)
5	NC	No Connection
6	DTMG	Timing Signal for Data
7	VSS	GND
8	DCLK	Dot Clock
9	VSS	GND
10	NC	No Connection
11	VSS	GND
12	B5	Blue Data
13	B4	
14	B3	
15	VSS	GND
16	B2	Blue Data
17	B1	
18	B0	
19	VSS	GND
20	G5	Green Data
21	G4	
22	G3	
23	VSS	GND
24	G2	Green Data
25	G1	
26	G0	
27	VSS	GND
28	R5	Red Data
29	R4	
30	R3	
31	VSS	GND
32	R2	Red Data
33	R1	
34	R0	
35	VSS	GND
36	DIM	NOTE A
37	NC	No Connection
38	NC	No Connection
39	NC	No Connection
40	NC	No Connection

Note A: Normal brightness: 0V or 0% PWM duty; Brightness control: 0V to 3.3V DC or 0% to 100% PWM duty.

The backlight connector (CN2) is SM02(8.0)B-BHS-1-TB(LF)(SN), and pin assignment is as below:

Pin No.	Signal	Signal
1	VLED	12VDC
2	GND	Ground

9.2 TIMING CHART

DTMG (Data Enable) is the signal of valid data, which needs to be set by relative signals such as Hsync and Vsync defined as below. For this display, only DCLK and DCLK are the essential signals. Hsync and Vsync are not necessary to connect to display interface after DTMG has been generated and input.

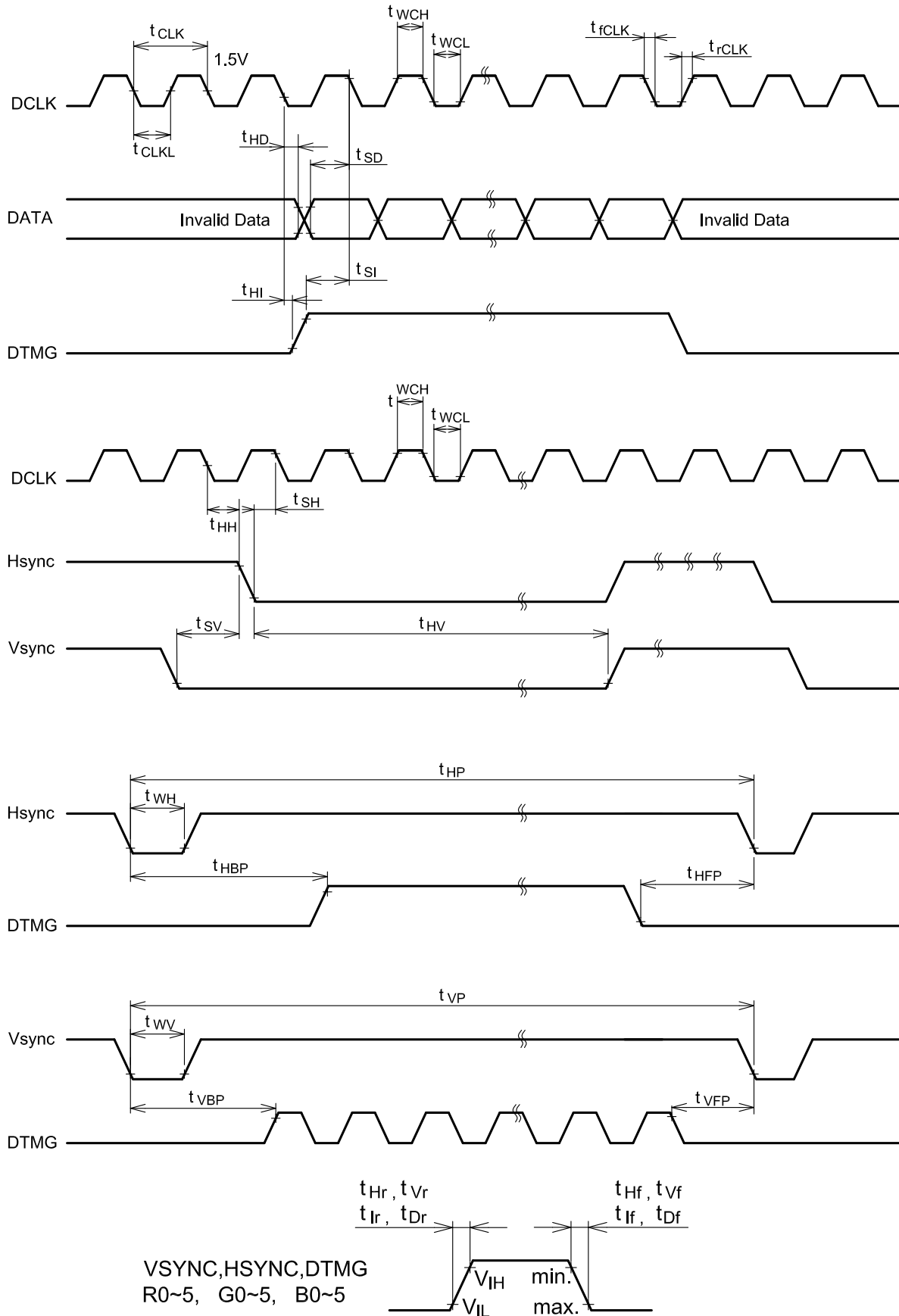

Data is latched by falling edge triggered DCLK

9.3 INTERFACE TIMING SPECIFICATIONS

Item		Symbol	Min.	Typ.	Max.	Unit
DCLK	Cycle time	$1/t_{CLK}$	30	33	36	MHZ
	Low level Width	t_{WCL}	8	-	-	ns
	High level Width	t_{WCH}	8	-	-	
	Rise time	t_{rCLK}	-	-	4	
	Fall time	t_{fCLK}	-	-	4	
	Duty	D	0.45	0.5	0.55	
Hsync	Set up time	t_{SH}	4	-	-	ns
	Hold time	t_{HH}	10	-	-	
	Cycle	t_{HP}	840	1056	1500	tCLK
	Valid width	t_{WH}	5	128	-	
	Rise/Fall time	t_{Hr}, t_{Hf}	-	-	30	ns
Vsync	Set up	t_{SV}	0	-	-	tCLK
	Hold	t_{HV}	2	-	-	
	Cycle	t_{VP}	483	525	640	tHP
	Valid width	t_{WV}	1	2	-	
	Rise/Fall time	t_{Vr}, t_{Vf}	-	-	50	ns
DTMG	Set up time	t_{SI}	4	-	-	ns
	Hold time	t_{HI}	4	-	-	
	Rise/Fall time	t_{Ir}, t_{If}	-	-	4	ns
	Horizontal back porch	t_{HBP}	10	216	-	tCLK
	Horizontal front porch	t_{HFP}	30	40	-	
	Vertical back porch	t_{VBP}	2	34	-	tHP
	Vertical front porch	t_{VFP}	1	11	-	

9.4 POWER SEQUENCE

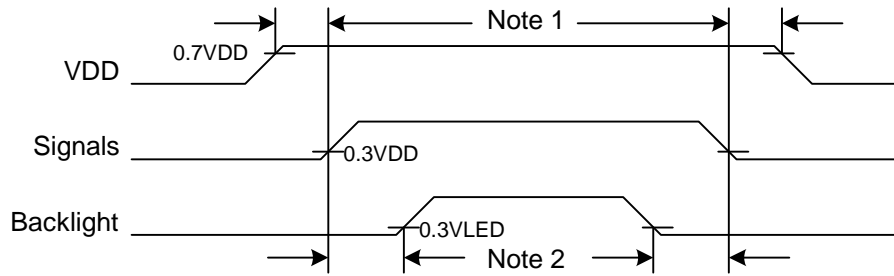

Fig. 8.7 Power Sequence Timing

Note 1: In order to avoid any damages, VDD has to be applied before all other signals. The opposite is true for power off where VDD has to be remained on until all other signals have been switch off. The recommended time period is 1 second.

Note 2: In order to avoid showing uncompleted patterns in transient state. It is recommended that switching the backlight on is delayed for 1 second after the signals have been applied. The opposite is true for power off where the backlight has to be switched off 1 second before the signals are removed.

9.5 DATA INPUT for DISPLAY COLOR

	COLOR & Gray Scale	Data Signal																	
		R5	R4	R3	R2	R1	R0	G5	G4	G3	G2	G1	G0	B5	B4	B3	B2	B1	B0
Basic Color	Black	0	0	0	0	0	0	0	0	0	0	0	0	0	0	0	0	0	0
	Red (63)	1	1	1	1	1	1	0	0	0	0	0	0	0	0	0	0	0	0
	Green (63)	0	0	0	0	0	0	1	1	1	1	1	1	0	0	0	0	0	0
	Blue (63)	0	0	0	0	0	0	0	0	0	0	0	0	1	1	1	1	1	1
	Cyan	0	0	0	0	0	0	1	1	1	1	1	1	1	1	1	1	1	1
	Magenta	1	1	1	1	1	1	0	0	0	0	0	0	1	1	1	1	1	1
	Yellow	1	1	1	1	1	1	1	1	1	1	1	1	0	0	0	0	0	0
	White	1	1	1	1	1	1	1	1	1	1	1	1	1	1	1	1	1	1
Red	Red (0)	0	0	0	0	0	0	0	0	0	0	0	0	0	0	0	0	0	0
	Red (1)	0	0	0	0	0	1	0	0	0	0	0	0	0	0	0	0	0	0
	:	:	:	:	:	:	:	:	:	:	:	:	:	:	:	:	:	:	:
	:	:	:	:	:	:	:	:	:	:	:	:	:	:	:	:	:	:	:
	Red (62)	1	1	1	1	1	0	0	0	0	0	0	0	0	0	0	0	0	0
	Red (63)	1	1	1	1	1	1	0	0	0	0	0	0	0	0	0	0	0	0
Green	Green (0)	0	0	0	0	0	0	0	0	0	0	0	0	0	0	0	0	0	0
	Green (1)	0	0	0	0	0	0	0	0	0	0	1	0	0	0	0	0	0	0
	:	:	:	:	:	:	:	:	:	:	:	:	:	:	:	:	:	:	:
	:	:	:	:	:	:	:	:	:	:	:	:	:	:	:	:	:	:	:
	Green (62)	0	0	0	0	0	0	1	1	1	1	1	0	0	0	0	0	0	0
	Green (63)	0	0	0	0	0	0	1	1	1	1	1	1	0	0	0	0	0	0
Blue	Blue (0)	0	0	0	0	0	0	0	0	0	0	0	0	0	0	0	0	0	0
	Blue (1)	0	0	0	0	0	0	0	0	0	0	0	0	0	0	0	0	0	1
	:	:	:	:	:	:	:	:	:	:	:	:	:	:	:	:	:	:	:
	:	:	:	:	:	:	:	:	:	:	:	:	:	:	:	:	:	:	:
	Blue (62)	0	0	0	0	0	0	0	0	0	0	0	0	1	1	1	1	1	0
	Blue (63)	0	0	0	0	0	0	0	0	0	0	0	0	1	1	1	1	1	1

9.6 SCAN DIRECTION

Scan direction is available to be switched as below by setting CN1's L/R & U/D pin.



L/R : L , U/D : L



L/R : H , U/D : L



L/R : L , U/D : H



L/R : H , U/D : H

10. OUTLINE DIMENSIONS

10.1 FRONT VIEW

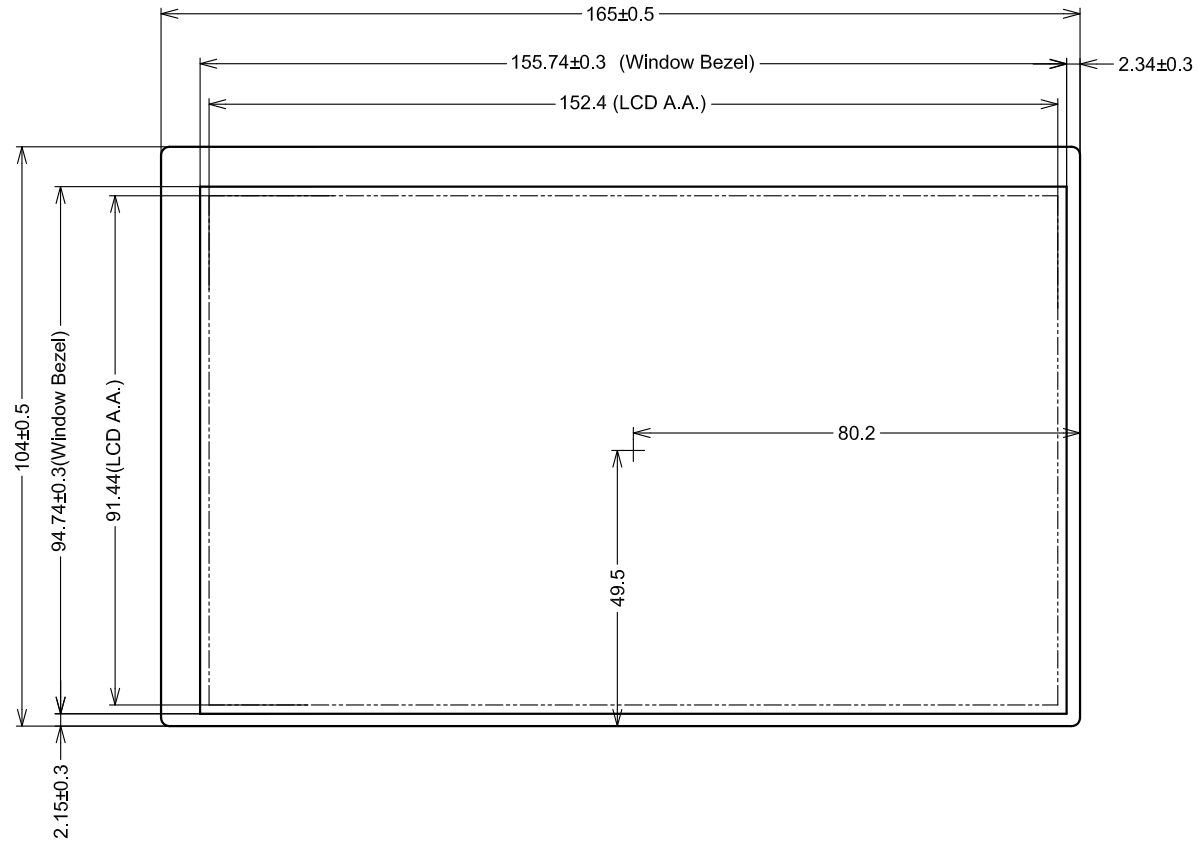

Scale : NTS
Unit : mm

10.2 REAR VIEW

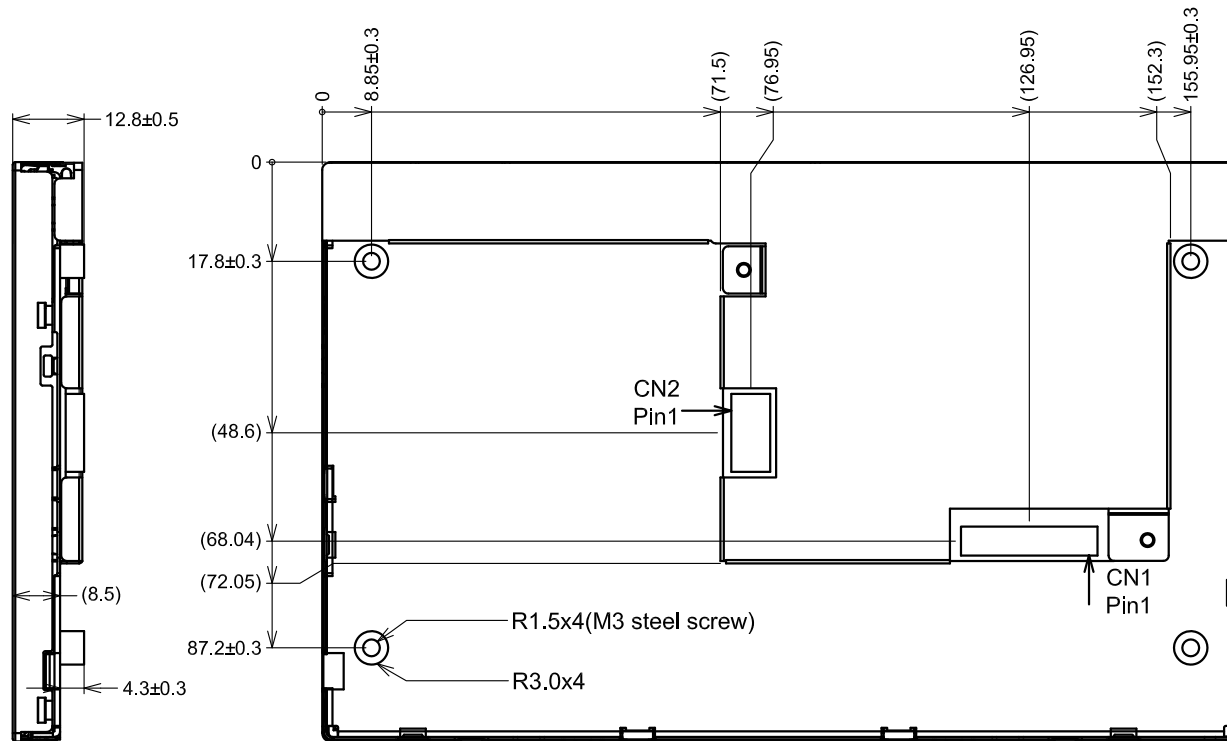

** Undefined tolerance is 0.5mm

Scale : NTS
Unit : mm

11. APPEARANCE STANDARD

The appearance inspection is performed in a dark room around 2000 lx based on the conditions as below:

- The distance between inspector's eyes and display is 30 cm.
- The viewing zone is defined with angle θ shown in Fig. 11.1 The inspection should be performed within 45° when display is shut down. The inspection should be performed within 5° when display is power on.

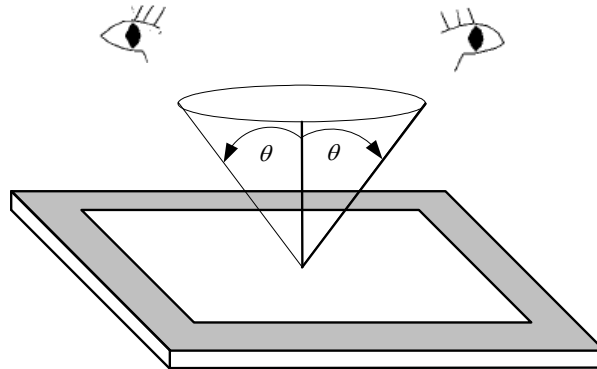

Fig 11.1

11.1 THE DEFINITION OF LCD ZONE

LCD panel is divided into 3 areas as shown in Fig.11.2 for appearance specification in next section. A zone is the LCD active area (dot area); B zone is the area, which extended 1 mm out from LCD active area; C zone is the area between B zone and metal frame.

In terms of housing design, B zone is the recommended window area customers' housing should be located in.

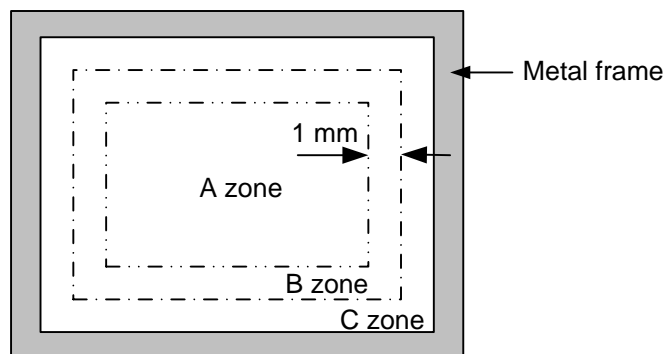

Fig 11.2

11.2 LCD APPEARANCE SPECIFICATION

The specification as below is defined as the amount of unexpected phenomenon or material in different zones of LCD panel. The definitions of length, width and average diameter using in the table are shown in Fig. 11.3 and Fig. 11.4.

Item	Criteria				Applied zone
	Length (mm)	Width (mm)	Maximum number	Minimum space	
Scratches	Ignored	$W \leq 0.01$	Ignored	-	A
	$L \leq 40$	$W \leq 0.02$	10	-	
	$L \leq 20$	$W \leq 0.04$	10	-	
	Round (Dot Shape)				
	Average diameter (mm)		Maximum number	Minimum space	
	$D \leq 0.2$		Ignore	-	
	$D \leq 0.4$		10	-	
	Dent	Serious one is not allowed			
Wrinkles in polarizer	Serious one is not allowed				A
Bubbles on polarizer	Average diameter (mm)		Maximum number		A
	$D \leq 0.3$		Ignored		
	$D \leq 0.5$		10		
	$D \leq 1.0$		5		
1) Stains 2) Foreign Materials 3) Dark Spot	Filamentous (Line shape)				A
	Length (mm)		Width (mm)		
	Ignored		$W \leq 0.02$		
	$L \leq 2.0$		$W \leq 0.03$		
	$L \leq 1.0$		$W \leq 0.06$		
	Round (Dot shape)				A
	Average diameter (mm)		Maximum number		
	$D \leq 0.22$		Ignored		
	$D \leq 0.33$		5		
	$D > 0.33$		0		
	In total		Filamentous + Round=10		
	Those wiped out easily are acceptable				
	Dot-Defect (Note 1)	Bright dot-defect		Type	Maximum number
1 dot				4	
2 adjacent dot				1	
3 adjacent dot or above				Not allowed	
Density				$2(\phi 20\text{mm})$	
In total		5			
Dark dot-defect		1 dot	5		
		2 adjacent dot	2		
		3 adjacent dot or above	Not allowed		
		Density	$3(\phi 20\text{mm})$		
		In total		5	
In total		10			

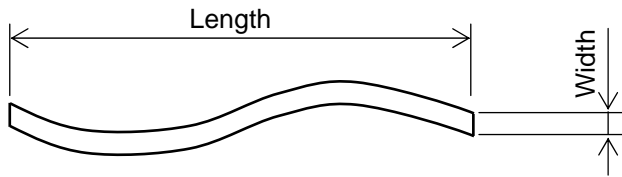

Fig 11.3

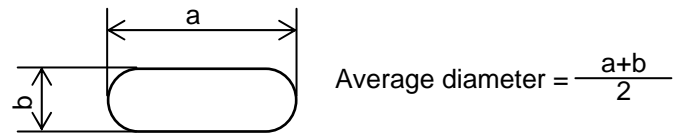

Fig 11.4

Note 1: The definitions of dot defect are as below:

- The defect area of the dot must be bigger than half of a dot.
- For bright dot-defect, showing black pattern, the dot's brightness must be over 30% brighter than others.
- For dark dot-defect, showing white pattern, the dot's brightness must be under 70% darker than others.
- The definition of 1-dot-defect is the defect-dot, which is isolated and no adjacent defect-dot.
- The definition of adjacent dot is shown as Fig. 11.5.
- The Density of dot defect is defined in the area within diameter $\phi = 20\text{mm}$.

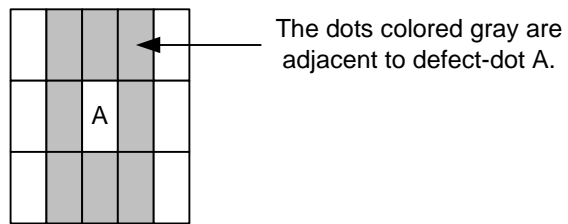

Fig 11.5

12. PRECAUTIONS

12.1 PRECAUTIONS OF ESD

- 1) Before handling the display, please ensure your body has been connected to ground to avoid any damages by ESD. Also, do not touch display's interface directly when assembling.
- 2) Please remove the protection film very slowly before turning on the display to avoid generating ESD.

12.2 PRECAUTIONS OF HANDLING

- 1) In order to keep the appearance of display in good condition, please do not rub any surfaces of the displays by sharp tools harder than 3H, especially touch panel, metal frame and polarizer.
- 2) Please do not pile the displays in order to avoid any scars leaving on the display. In order to avoid any injuries, please pay more attention for the edges of glasses and metal frame, and wear finger cots to protect yourself and the display before working on it.
- 3) Touching the display area or the terminal pins with bare hand is prohibited. This is because it will stain the display area and cause poor insulation between terminal pins, and might affect display's electrical characteristics furthermore.
- 4) Do not use any harmful chemicals such as acetone, toluene, and isopropyl alcohol to clean display's surfaces.
- 5) Please use soft cloth or absorbent cotton with ethanol to clean the display by gently wiping. Moreover, when wiping the display, please wipe it by horizontal or vertical direction instead of circling to prevent leaving scars on the display's surface, especially polarizer.
- 6) Please wipe any unknown liquids immediately such as saliva, water or dew on the display to avoid color fading or any permanently damages.
- 7) Maximum pressure to the surface of the display must be less than 1.96×10^4 Pa. If the area of adding pressure is less than 1 cm^2 , the maximum pressure must be less than 1.96N.

12.3 PRECAUTIONS OF OPERATING

- 1) Please input signals and voltages to the displays according to the values defined in the section of electrical characteristics to obtain the best performance. Any voltages over than absolute maximum rating will cause permanent damages to this display. Also, any timing of the signals out of this specification would cause unexpected performance.
- 2) When the display is operating at significant low temperature, the response time will be slower than it at 25 C° . In high temperature, the color will be slightly dark and blue compared to original pattern. However, these are temperature-related phenomenon of LCD and it will not cause permanent damages to the display when used within the operating temperature.
- 3) The use of screen saver or sleep mode is recommended when static images are likely for long periods of time. This is to avoid the possibility of image sticking.
- 4) Spike noise can cause malfunction of the circuit. The recommended limitation of spike noise is no bigger than $\pm 100 \text{ mV}$.

12.4 PRECAUTIONS of STORAGE

If the displays are going to be stored for years, please be aware the following notices.

- 1) Please store the displays in a dark room to avoid any damages from sunlight and other sources of UV light.
- 2) The recommended long term storage temperature is between 10 C° ~35 C° and 55%~75% humidity to avoid causing bubbles between polarizer and LCD glasses, and polarizer peeling from LCD glasses.
- 3) It would be better to keep the displays in the container, which is shipped from Hitachi, and do not unpack it.
- 4) Please do not stick any labels on the display surface for a long time, especially on the polarizer.

13. DESIGNATION OF LOT MARK

1) The lot mark is showing in Fig.13.3. First 4 digits are used to represent production lot, T represented made in Taiwan, and the last 5 digits are the serial number.

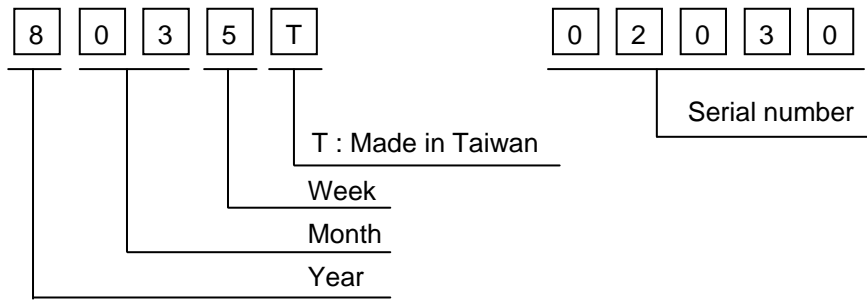

2) The tables as below are showing what the first 4 digits of lot mark are shorted for.

Year	Mark
2010	0
2011	1
2012	2
2013	3
2014	4

Month	Mark	Month	Mark
1	01	7	07
2	02	8	08
3	03	9	09
4	04	10	10
5	05	11	11
6	06	12	12

Week (Days)	Mark
1~7	1
8~14	2
15~21	3
22~28	4
29~31	5

3) Except letters I and O, revision number will be shown on lot mark and following letters A to Z.

4) The location of the lot mark is on the back of the display shown in Fig. 13.3.



Fig 13.3