

HITACHI

KAOHSIUNG HITACHI
ELECTRONICS CO.,LTD
P.O. BOX 26-27
2,13TH EAST ST. K.E.P.Z.
KAOHSIUNG TAIWAN R.O.C.
TEL:(07) 8215811 (7 LINE)
FAX:(07) 821-5815

FOR MESSRS : _____

DATE : Nov.29th,2010

CUSTOMER'S ACCEPTANCE SPECIFICATIONS TX11D04VM2AAA CONTENTS

No.	ITEM	SHEET No.	PAGE
1	COVER	7B64PS 2701-TX11D04VM2AAA-2	1-1/1
2	RECORD OF REVISION	7B64PS 2702-TX11D04VM2AAA-2	2-1/1
3	GENERAL DATA	7B64PS 2703-TX11D04VM2AAA-2	3-1/1
4	ABSOLUTE MAXIMUM RATINGS	7B64PS 2704-TX11D04VM2AAA-2	4-1/1
5	ELECTRICAL CHARACTERISTICS	7B64PS 2705-TX11D04VM2AAA-2	5-1/1
6	OPTICAL CHARACTERISTICS	7B64PS 2706-TX11D04VM2AAA-2	6-1/2~2/2
7	BLOCK DIAGRAM	7B64PS 2707-TX11D04VM2AAA-2	7-1/1
8	RELIABILITY TESTS	7B64PS 2708-TX11D04VM2AAA-2	8-1/1
9	LCD INTERFACE	7B64PS 2709-TX11D04VM2AAA-2	9-1/5~9-5/5
10	OUTLINE DIMENSIONAL	7B63PS 2710-TX11D04VM2AAA-2	10-1/1
11	APPEARANCE STANDARD	7B64PS 2711-TX11D04VM2AAA-2	11-1/3~3/3
12	PRECAUTIONS	7B64PS 2712-TX11D04VM2AAA-2	12-1/1~2/2
13	DESIGNATION OF LOT MARK	7B64PS 2713-TX11D04VM2AAA-2	13-1/1

* When product will be discontinued, customer will be informed by HITACHI with six months prior announcement.

ACCEPTED BY; _____

PROPOSED BY; _____

Dan Cheng

KAOHSIUNG HITACHI ELECTRONICS CO.,LTD.	Sh. No.	7B64PS 2701-TX11D04VM2AAA-2	PAGE	1-1/1
---	------------	-----------------------------	------	-------

RECORD OF REVISION

DATE	SHEET No.	SUMMARY																						
Nov.29,'10	7B64PS 2701- TX11D04VM2AAA-2 Page 13-1/1	<p>13 DESIGNATION OF LOT MARK</p> <p>Revised :</p> <div style="display: flex; justify-content: space-around; align-items: flex-start;"> <div style="text-align: center;"> <table border="1" style="border-collapse: collapse;"> <tr> <td style="padding: 2px 5px;">9</td> <td style="padding: 2px 5px;">0</td> <td style="padding: 2px 5px;">4</td> <td style="padding: 2px 5px;">4</td> <td style="padding: 2px 5px;">C</td> </tr> </table> <div style="margin-top: 5px;"> <p style="margin-left: 10px;">C: Made in China</p> <p style="margin-left: 10px;">Week</p> <p style="margin-left: 10px;">Month</p> <p style="margin-left: 10px;">Year</p> </div> </div> <div style="text-align: center;"> <table border="1" style="border-collapse: collapse;"> <tr> <td style="padding: 2px 5px;">5</td> <td style="padding: 2px 5px;">0</td> <td style="padding: 2px 5px;">1</td> <td style="padding: 2px 5px;">6</td> <td style="padding: 2px 5px;">8</td> <td style="padding: 2px 5px;">8</td> </tr> </table> <div style="margin-top: 5px;"> <p style="margin-left: 10px;">Serial number</p> </div> </div> </div> <p style="text-align: center; margin: 10px 0;">↓</p> <div style="display: flex; justify-content: space-around; align-items: flex-start;"> <div style="text-align: center;"> <table border="1" style="border-collapse: collapse;"> <tr> <td style="padding: 2px 5px;">9</td> <td style="padding: 2px 5px;">0</td> <td style="padding: 2px 5px;">4</td> <td style="padding: 2px 5px;">4</td> <td style="padding: 2px 5px;">T</td> </tr> </table> <div style="margin-top: 5px;"> <p style="margin-left: 10px;">Week</p> <p style="margin-left: 10px;">Month</p> <p style="margin-left: 10px;">Year</p> </div> </div> <div style="text-align: center;"> <table border="1" style="border-collapse: collapse;"> <tr> <td style="padding: 2px 5px;">5</td> <td style="padding: 2px 5px;">0</td> <td style="padding: 2px 5px;">1</td> <td style="padding: 2px 5px;">6</td> <td style="padding: 2px 5px;">8</td> <td style="padding: 2px 5px;">8</td> </tr> </table> <div style="margin-top: 5px;"> <p style="margin-left: 10px;">Serial number</p> </div> </div> </div>	9	0	4	4	C	5	0	1	6	8	8	9	0	4	4	T	5	0	1	6	8	8
9	0	4	4	C																				
5	0	1	6	8	8																			
9	0	4	4	T																				
5	0	1	6	8	8																			

3.GENERAL DATA

3.1 DISPLAY FEATURES

This module is a 4.3" WQVGA of 16:9 format amorphous silicon TFT. The pixel format is vertical stripe and sub pixels are arranged as R(red), G(green), B(blue) sequentially. This display is RoHS compliant, and COG (chip on glass) technology and LED backlight are applied on this display.

(1) Part Name	TX11D04VM2AAA
(2) Module Dimensions	105.5(W) mm x 67.2(H) mm x 2.9(D) mm typ.
(3) LCD Active Area	95.04(W) mm x 53.856(H) mm
(4) Dot Pitch	0.066(W) mm x 3(R, G, B)(W) x 0.198(H) mm
(5) Resolution	480 x 3(RGB)(W) x 272(H) dots
(6) Color Pixel Arrangement	R, G, B Vertical stripe
(7) LCD Type	Transmissive Color TFT; Normally White
(8) Display Type	Active Matrix
(9) Number of Colors	16.7M Color
(10) Backlight	7 LEDs serial
(11) Weight	(45) g (typ.)
(12) Interface	C-MOS; 24-bit RGB; 40 pins
(13) Power Supply Voltage	3.3V for LCD; (23.1)V for Backlight
(14) Power Consumption	49.5 mW for LCD; (462)mW for backlight
(15) Viewing Direction	12 O'clock (The direction without image inversion and least brightness change)

4. ABSOLUTE MAXIMUM RATINGS

Item	Symbol	Min.	Max.	Unit	Remarks
Supply Voltage	VDD	0.3	5.0	V	-
Input Voltage of Logic	VI	-0.3	VDD+0.3	V	Note 1
Operating Temperature	Top	-20	70	°C	Note 2
Storage Temperature	Tst	-30	80	°C	Note 2
LED Backlight Forward Current	ILED	-	25	mA	Note 3

Note 1: The rating is defined for the signal voltages of the interface such as DTMG, Hsync, Vsync, DISP, DCLK and RGB data bus.

Note 2: The maximum rating is defined as above based on the temperature on the panel surface, which might be different from ambient temperature after assembling the panel into the application. Moreover, some temperature-related phenomenon as below needed to be noticed:

- Background color, contrast and response time would be different in temperatures other than 25°C.
- Operating under high temperature will shorten LED lifetime.

Note 3: Fig. 4.1 shows the maximum rating of LED forward current against temperature. The backlight unit in this display has been set to 20 mA per LED. This is within the range when operating the display between -20~70°C

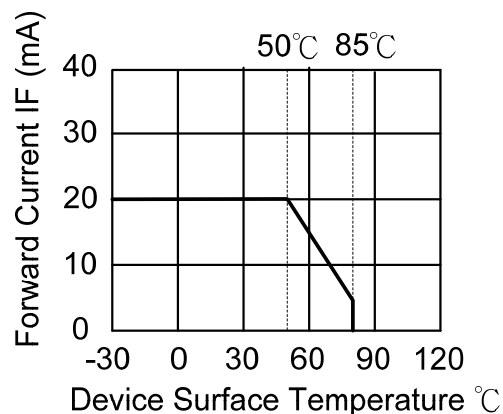

Fig 4.1

5. ELECTRICAL CHARACTERISTICS

5.1 LCD CHARACTERISTICS

$T_a = 25\text{ }^\circ\text{C}$, $V_{SS} = 0\text{V}$

Item	Symbol	Condition	Min.	Typ.	Max.	Unit	Remarks
Power Supply Voltage	VDD	-	3.0	3.3	3.6	V	-
Input Voltage of Logic	VIH	"H" level	0.7xVDD	-	VDD	V	Note 1
	VIL	"L" level	VSS	-	0.3xVDD		
Power Supply Current	IDD	-	-	15	-	mA	Note 2
Vsync Frequency	f_v	-	-	60	90	Hz	-
Hsync Frequency	f_H	-	-	17.14	-	KHz	-
DCLK Frequency	f_{CLK}	-	-	9.0	15.0	MHz	-

Note 1: The rating is defined for the signal voltages of the interface such as DTMG, Hsync, Vsync, DISP DCLK and RGB data bus.

Note 2: An all black check pattern is used when measuring IDD, f_v is set to 60 Hz.

5.2 BACKLIGHT CHARACTERISTICS

$T_a = 25\text{ }^\circ\text{C}$

Item	Symbol	Condition	Min.	Typ.	Max.	Unit	Remarks
LED Input Voltage	VLED	Backlight Unit	-	(23.1)	-	V	Note1
LED Forward Current	ILED	Backlight Unit	10	20	20	mA	-
LED Lifetime	-	ILED = 20 mA	(10K)	(20K)	-	hrs	Note 2

Note 1: Fig. 5.1 shows the LED backlight circuit. The circuit has 7 LEDs in total.

Note 2: The estimated lifetime is specified as the time to reduce 50% brightness by applying 20 mA at $25\text{ }^\circ\text{C}$.

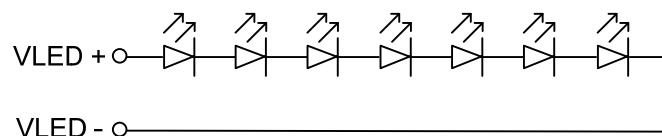

Fig. 5.1

6. OPTICAL CHARACTERISTICS

The optical characteristics are measured based on the conditions as below:

- Supplying the signals and voltages defined in the section of electrical characteristics.
- The backlight unit needs to be turned on for 30 minutes.
- The ambient temperature is 25°C.
- In the dark room around 500~1000 lx, the equipment has been set for the measurements as shown in Fig 6.1.

$$T_a = 25^\circ\text{C}, f_v = 60\text{ Hz}, VDD = 3.3\text{V}$$

Item	Symbol	Condition	Min.	Typ.	Max.	Unit	Remarks
Brightness of White	-	$\phi = 0^\circ, \theta = 0^\circ$, ILED= 20 mA	300	350	-	cd/m ²	Note 1
Brightness Uniformity	-		75	80	-	%	Note 2
Contrast Ratio	CR		450	550	-	-	Note 3
Response Time (Rising + Falling)	T _r + T _f	$\phi = 0^\circ, \theta = 0^\circ$	-	(30)	-	ms	Note 4
NTSC Ratio	-	$\phi = 0^\circ, \theta = 0^\circ$	-	(50)	-	%	-
Viewing Angle	θ_x	$\phi = 0^\circ, CR \geq 10$	50	70	-	Degree	Note 5
	$\theta_{x'}$	$\phi = 180^\circ, CR \geq 10$	50	70	-		
	θ_y	$\phi = 90^\circ, CR \geq 10$	40	60	-		
	$\theta_{y'}$	$\phi = 270^\circ, CR \geq 10$	50	70	-		
Color Chromaticity	Red	x	(0.55)	0.60	(0.65)	-	Note 6
		y	(0.32)	0.37	(0.42)		
	Green	x	(0.30)	0.35	(0.40)		
		y	(0.52)	0.57	(0.62)		
	Blue	x	(0.10)	0.15	(0.20)		
		y	(0.04)	0.09	(0.14)		
	White	x	(0.26)	0.31	(0.36)		
		y	(0.28)	0.33	(0.38)		

Note 1: The brightness is measured from center point of the panel, P5 in Fig. 6.2, for the typical value.

Note 2: The brightness uniformity is calculated by the equation as below:

$$\text{Brightness uniformity} = \frac{\text{Min. Brightness}}{\text{Max. Brightness}} \times 100\%$$

, which is based on the brightness values of the 9 points measured by BM-7 as shown in Fig. 6.2.

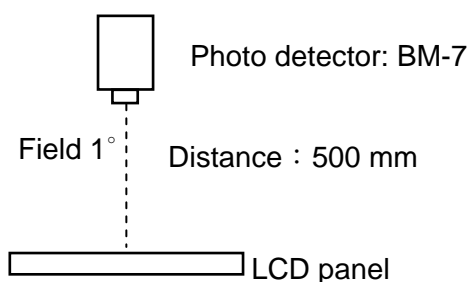

Fig. 6.1

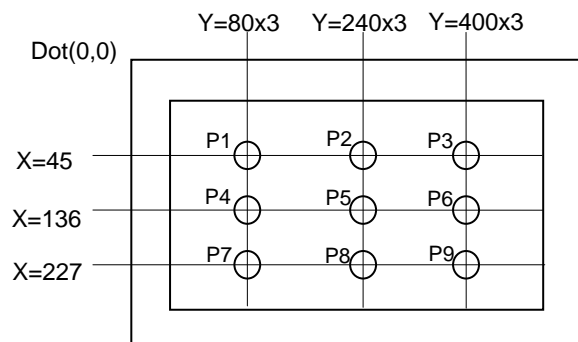

Fig. 6.2

Note 3: The Contrast ratio is measured from the center point of the panel, P5, and defined as the following equation:

$$CR = \frac{\text{Brightness of White}}{\text{Brightness of Black}}$$

Note 4: The definition of response time is shown in Fig. 6.3. The rising time is the period from 90% brightness to 10% brightness when the data is from white to black. Oppositely, falling time is the period from 10% brightness rising to 90% brightness.

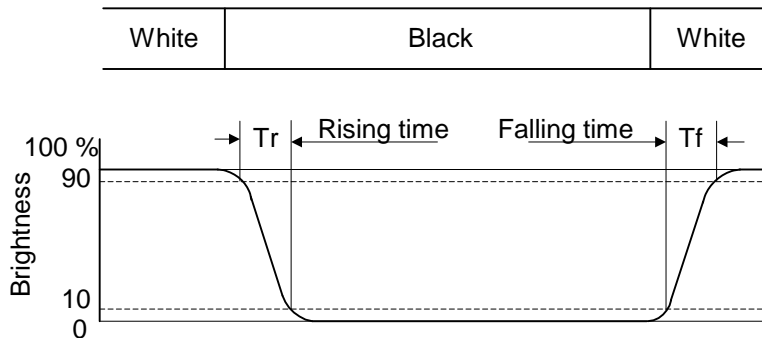

Fig . 6.3

Note 5: The definition of viewing angle is shown in Fig. 6.4. Angle ϕ is used to represent viewing directions, for instance, $\phi = 270^\circ$ means 6 o'clock, and $\phi = 0^\circ$ means 3 o'clock. Moreover, angle θ is used to represent viewing angles from axis Z toward plane XY.

The viewing direction of this display is 12 o'clock, which means that a photograph with gray scale would not be reversed in color and the brightness change would be less from this direction. However, the best contrast peak would be located at 6 o'clock.

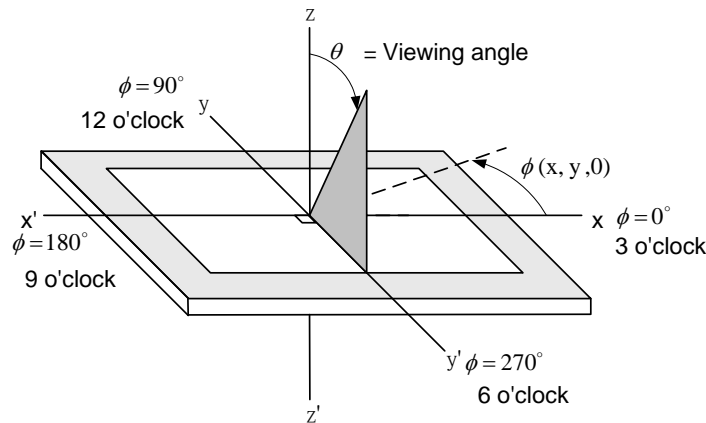
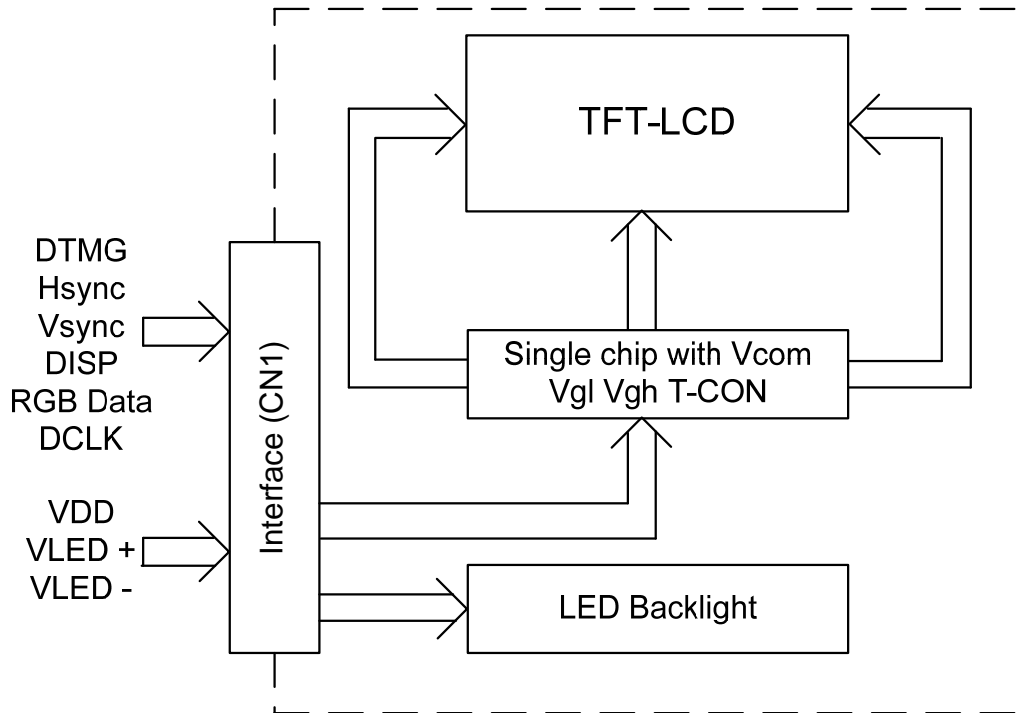

Fig 6.4

Note 6: The color chromaticity is measured from the center point of the panel, P5, as shown in Fig. 6.2.

7. BLOCK DIAGRAM



8. RELIABILITY TESTS

Test Item	Condition	
High Temperature	1) Operating 2) 70 °C	240 hrs
Low Temperature	1) Operating 2) -20 °C	240 hrs
High Temperature	1) Storage 2) 80 °C	240 hrs
Low Temperature	1) Storage 2) -30 °C	240 hrs
Thermal Shock	1) Non-Operating 2) -30 °C ↔ 80 °C 3) 0.5 hr ↔ 0.5 hr	100 cycles
High Temperature & Humidity	1) Operating 2) 60 °C & 90%RH 3) Without condensation 4) Note 4	240 hrs
Vibration	1) Non-Operating 2) 10~500 Hz 3) 1.5G 4) X, Y, and Z directions	1 hr for each direction
Mechanical Shock	1) Non-Operating 2) 2 ms 3) 50G 4) ±X, ±Y and ±Z directions	Once for each direction
ESD	1) Non-Operating 2) Tip: 150 pF, 330 Ω 3) Air discharge for glass: ± 8KV 4) Contact discharge for metal frame: ± 6KV	1) Glass: 9 points 2) Metalframe: 8 points

Note 1: Display functionalities are inspected under the conditions defined in the specification after the reliability tests.

Note 2: The display is not guaranteed for use in corrosive gas environments.

Note 3: All the appearance specifications are judged before the reliability tests.

Note 4: Under the condition of high temperature & humidity, if the temperature is higher than 60 °C, the humidity needs to be reduced as Fig. 8.1 shown.

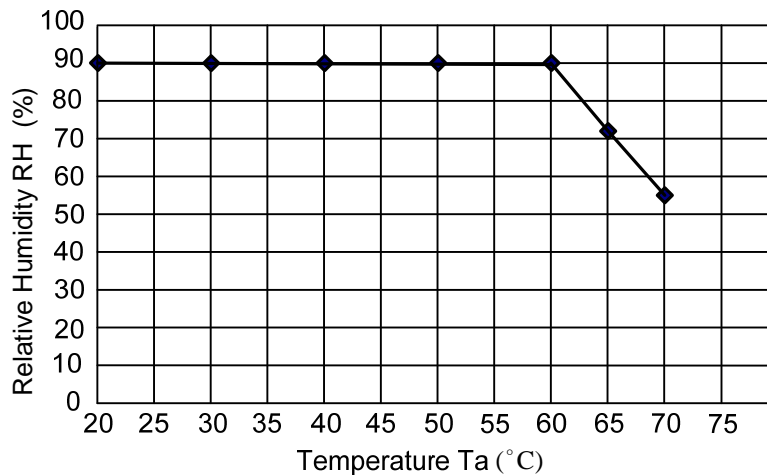

Fig. 8.1

9. LCD INTERFACE

9.1 INTERFACE PIN CONNECTIONS

The display interface connector is FH12 series made by Hirose (Thickness: $0.3 \pm 0.05\text{mm}$; Pitch: 0.5mm) and more details of the connector are shown in the section of outline dimension.

Pin assignment of LCD interface is as below:

Pin No.	Signal	Function	Pin No.	Signal	Function
1	VLED-	LED Ground	21	B0	Blue Data Bit0 (LSB)
2	VLED+	LED Power	22	B1	Blue Data Bit1
3	VSS	Ground	23	B2	Blue Data Bit2
4	VDD	Power Supply for Logic	24	B3	Blue Data Bit3
5	R0	Red Data Bit0 (LSB)	25	B4	Blue Data Bit4
6	R1	Red Data Bit1	26	B5	Blue Data Bit5
7	R2	Red Data Bit2	27	B6	Blue Data Bit6
8	R3	Red Data Bit3	28	B7	Blue Data Bit7 (MSB)
9	R4	Red Data Bit4	29	VSS	Ground
10	R5	Red Data Bit5	30	DCLK	Dot Data Clock
11	R6	Red Data Bit6	31	DISP	Note 1
12	R7	Red Data Bit7 (MSB)	32	Hsync	Horizontal Sync Signal
13	G0	Green Data Bit0 (LSB)	33	Vsync	Vertical Sync Signal
14	G1	Green Data Bit1	34	DTMG	Display Timing Signal
15	G2	Green Data Bit2	35	NC	No Connection
16	G3	Green Data Bit3	36	VSS	Ground
17	G4	Green Data Bit4	37	NC	No Connection
18	G5	Green Data Bit5	38	NC	No Connection
19	G6	Green Data Bit6	39	NC	No Connection
20	G7	Green Data Bit7 (MSB)	40	NC	No Connection

Note 1: DISP = "H": input data are valid

DISP = "L": input data are invalid and white display data is written automatically.

9.2 TIMING CHART

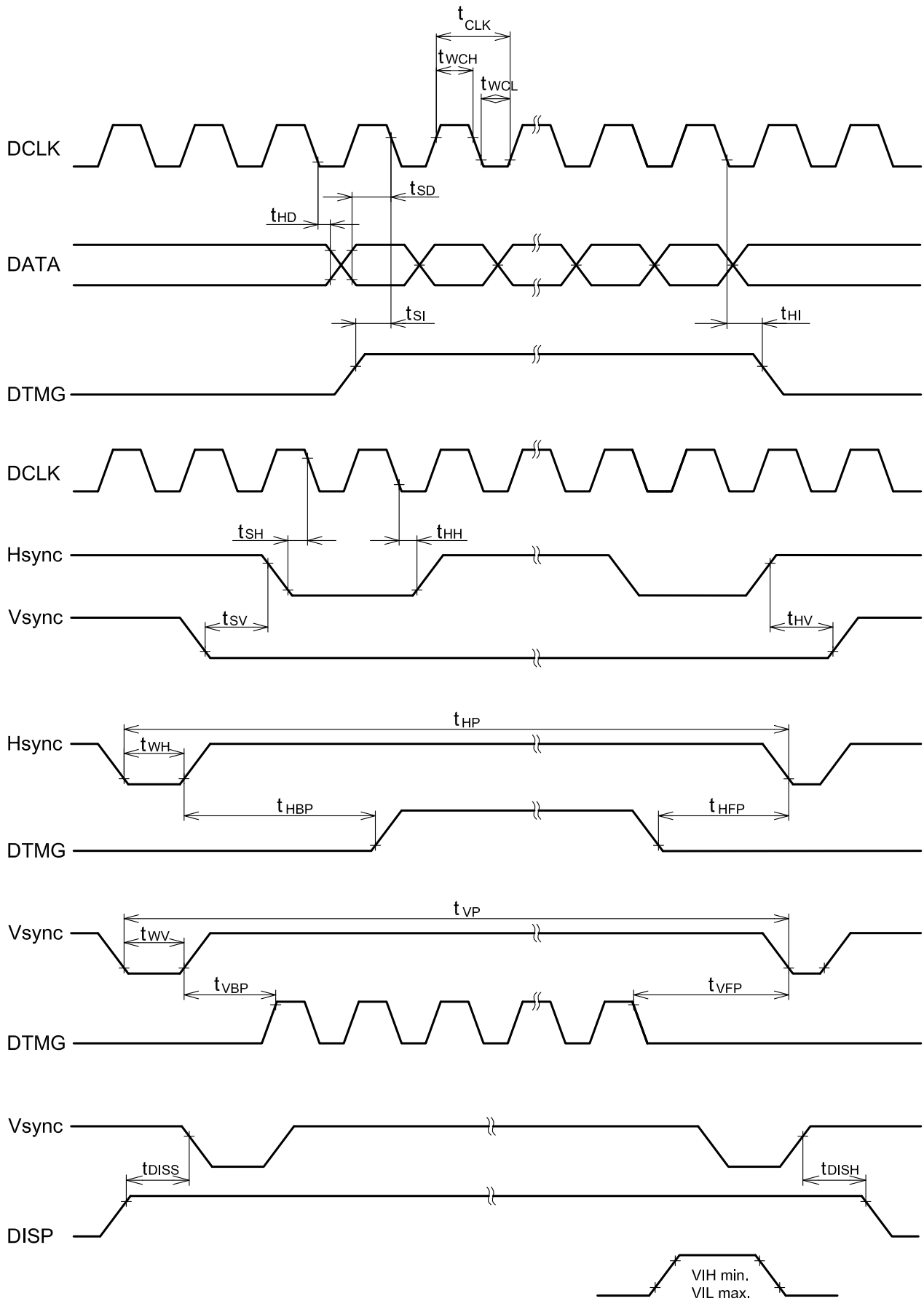

Note 1: Data is latched by falling edge of DCLK

9.3 INTERFACE TIMING SPECIFICATIONS

Item		Symbol	Min.	Typ.	Max.	Unit
DCLK	Cycle time	t_{CLK}	66.7	111.1	-	ns
	Low level Width	t_{WCL}	26.7	-	-	
	High level Width	t_{WCH}	26.7	-	-	
	Duty	D	0.45	0.5	0.55	-
Hsync	Set up time	t_{SH}	10	-	-	ns
	Hold time	t_{HH}	10	-	-	
	Cycle	t_{HP}	-	525	-	tCLK
	Valid width	t_{WH}	2	41	-	
Vsync	Set up	t_{SV}	10	-	-	tCLK
	Hold	t_{HV}	10	-	-	
	Cycle	t_{VP}	-	286	-	tHP
	Valid width	t_{WV}	1	10	-	
DTMG	Set up time	t_{SI}	10	-	-	ns
	Hold time	t_{HI}	10	-	-	
	Horizontal back porch	t_{HBP}	2	2	-	
	Horizontal front porch	t_{HFP}	2	2	-	
	Vertical back porch	t_{VBP}	1	2	-	tHP
	Vertical front porch	t_{VFP}	1	2	-	
Data	Set up time	t_{SD}	10	-	-	ns
	Hold time	t_{HD}	10	-	-	
DISP	Set up time	t_{DISS}	10	-	-	ns
	Hold time	t_{DISH}	10	-	-	

Note 1: $t_{WH} + t_{HBP} + t_{HFP} > 44$

9.4 POWER SEQUENCE

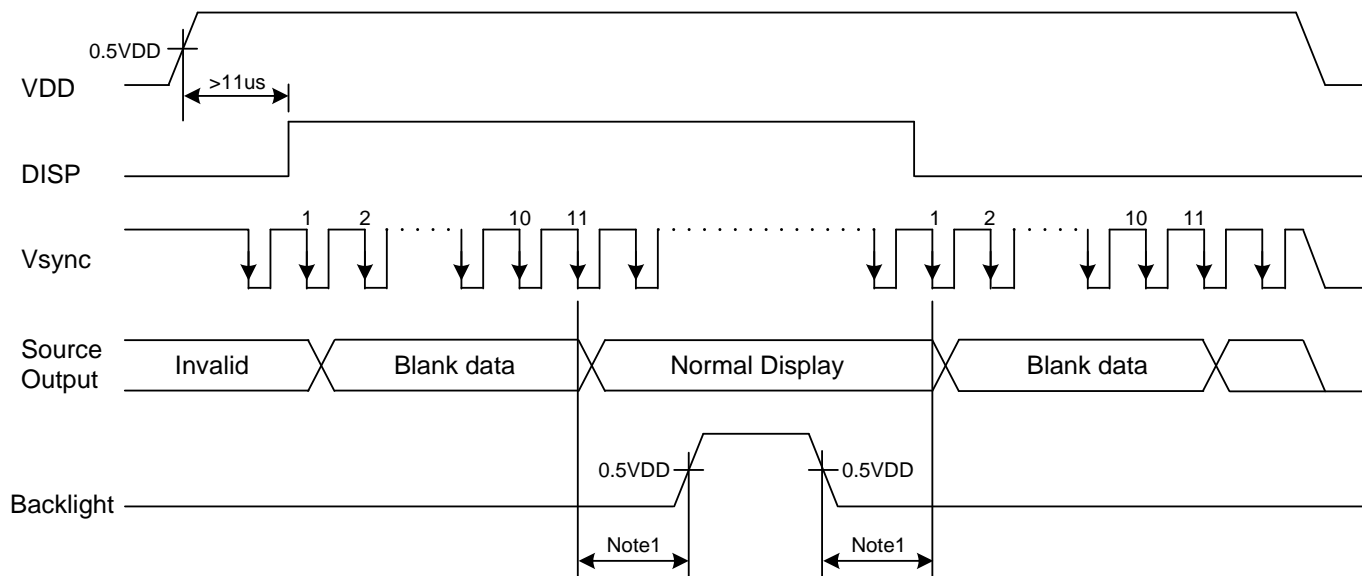

Note 1: In order to avoid showing uncompleted patterns in transient state. It is recommended that switching the backlight on is delayed for 0.1 second after the signals have been applied. The opposite is true for power Off where the backlight have to be switched off 0.1 second before the signals.

9.5 DATA INPUT for DISPLAY COLOR

color	Input	Red Data								Green Data								Blue Data							
		R7	R6	R5	R4	R3	R2	R1	R0	G7	G6	G5	G4	G3	G2	G1	G0	B7	B6	B5	B4	B3	B2	B1	B0
		MSB				LSB				MSB				LSB				MSB				LSB			
Basic Color	Black	0	0	0	0	0	0	0	0	0	0	0	0	0	0	0	0	0	0	0	0	0	0	0	0
	Red(0)	1	1	1	1	1	1	1	1	0	0	0	0	0	0	0	0	0	0	0	0	0	0	0	
	Green(0)	0	0	0	0	0	0	0	0	1	1	1	1	1	1	1	0	0	0	0	0	0	0	0	
	Blue(0)	0	0	0	0	0	0	0	0	0	0	0	0	0	0	0	1	1	1	1	1	1	1	1	
	Cyan	0	0	0	0	0	0	0	0	1	1	1	1	1	1	1	1	1	1	1	1	1	1	1	
	Magenta	1	1	1	1	1	1	1	1	0	0	0	0	0	0	0	1	1	1	1	1	1	1	1	
	Yellow	1	1	1	1	1	1	1	1	1	1	1	1	1	1	1	0	0	0	0	0	0	0	0	
	White	1	1	1	1	1	1	1	1	1	1	1	1	1	1	1	1	1	1	1	1	1	1	1	
Red	Black	0	0	0	0	0	0	0	0	0	0	0	0	0	0	0	0	0	0	0	0	0	0	0	
	Red(254)	0	0	0	0	0	0	0	1	0	0	0	0	0	0	0	0	0	0	0	0	0	0	0	
	Red(253)	0	0	0	0	0	0	1	0	0	0	0	0	0	0	0	0	0	0	0	0	0	0	0	
	:	:	:	:	:	:	:	:	:	:	:	:	:	:	:	:	:	:	:	:	:	:	:	:	
	:	:	:	:	:	:	:	:	:	:	:	:	:	:	:	:	:	:	:	:	:	:	:	:	
	Red(2)	1	1	1	1	1	1	1	1	0	0	0	0	0	0	0	0	0	0	0	0	0	0	0	
	Red(1)	1	1	1	1	1	1	1	0	0	0	0	0	0	0	0	0	0	0	0	0	0	0	0	
	Red(0)	1	1	1	1	1	1	1	1	0	0	0	0	0	0	0	0	0	0	0	0	0	0	0	
Green	Black	0	0	0	0	0	0	0	0	0	0	0	0	0	0	0	0	0	0	0	0	0	0	0	
	Green(254)	0	0	0	0	0	0	0	0	0	0	0	0	0	0	1	0	0	0	0	0	0	0	0	
	Green(253)	0	0	0	0	0	0	0	0	0	0	0	0	0	1	0	0	0	0	0	0	0	0	0	
	:	:	:	:	:	:	:	:	:	:	:	:	:	:	:	:	:	:	:	:	:	:	:	:	
	:	:	:	:	:	:	:	:	:	:	:	:	:	:	:	:	:	:	:	:	:	:	:	:	
	Green(2)	0	0	0	0	0	0	0	0	1	1	1	1	1	1	1	0	0	0	0	0	0	0	0	
	Green(1)	0	0	0	0	0	0	0	0	1	1	1	1	1	1	0	0	0	0	0	0	0	0	0	
	Green(0)	0	0	0	0	0	0	0	0	1	1	1	1	1	1	1	0	0	0	0	0	0	0	0	
Blue	Black	0	0	0	0	0	0	0	0	0	0	0	0	0	0	0	0	0	0	0	0	0	0	0	
	Blue(254)	0	0	0	0	0	0	0	0	0	0	0	0	0	0	0	0	0	0	0	0	0	0	1	
	Blue(253)	0	0	0	0	0	0	0	0	0	0	0	0	0	0	0	0	0	0	0	0	0	1	0	
	:	:	:	:	:	:	:	:	:	:	:	:	:	:	:	:	:	:	:	:	:	:	:	:	
	:	:	:	:	:	:	:	:	:	:	:	:	:	:	:	:	:	:	:	:	:	:	:	:	
	Blue(2)	0	0	0	0	0	0	0	0	0	0	0	0	0	0	0	1	1	1	1	1	1	1	1	
	Blue(1)	0	0	0	0	0	0	0	0	0	0	0	0	0	0	0	1	1	1	1	1	1	1	0	
	Blue(0)	0	0	0	0	0	0	0	0	0	0	0	0	0	0	0	1	1	1	1	1	1	1	1	

10. OUTLINE DIMENSIONS

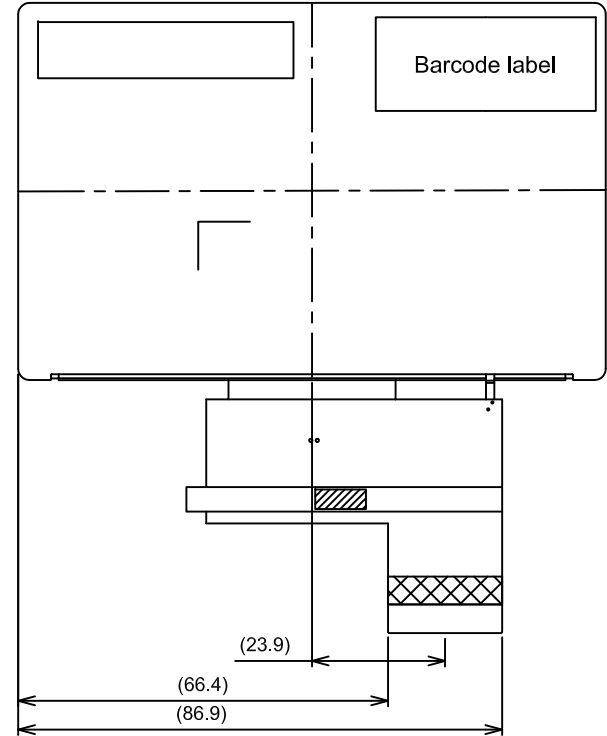
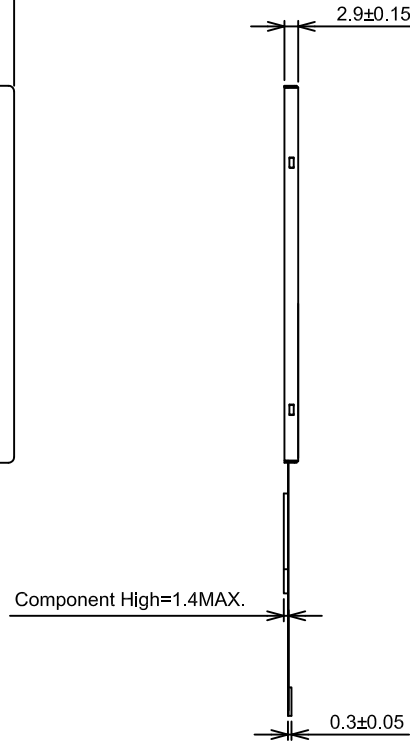
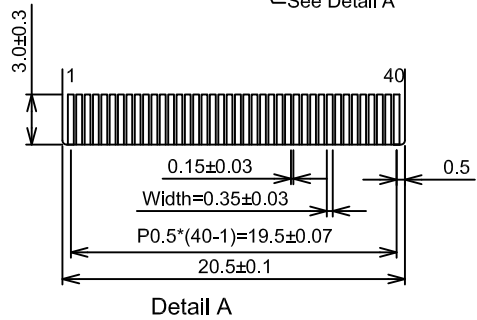
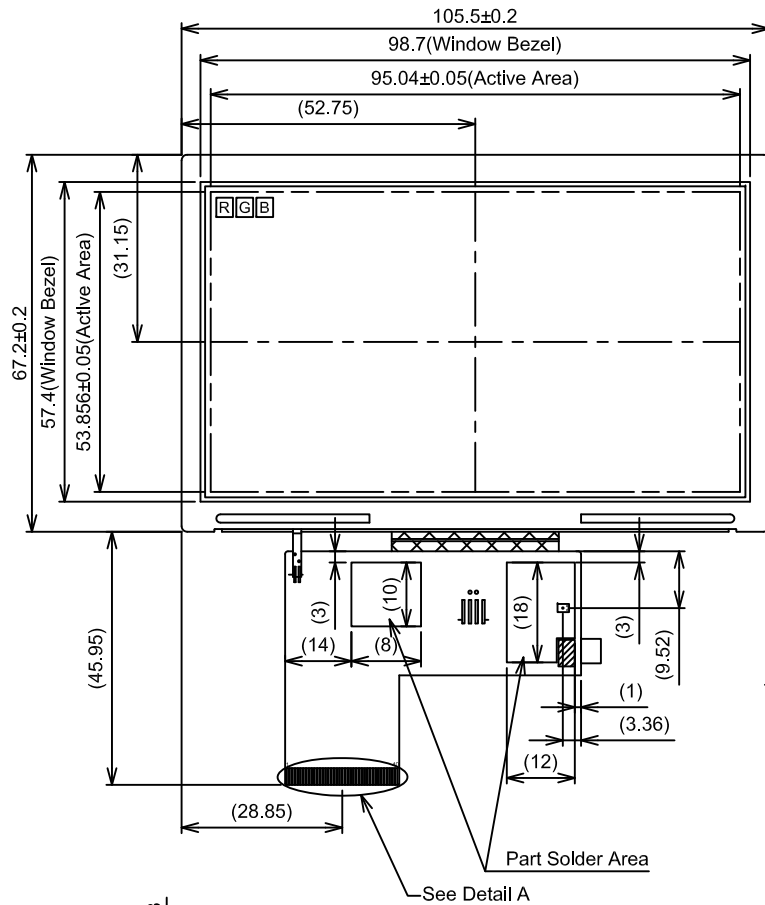

Scale : NTS
Unit : mm

11. APPEARANCE STANDARD

The appearance inspection is performed in a dark room around 600~1000 lx based on the conditions as below:

- The distance between inspector's eyes and display is 35 cm.
- The viewing zone is defined with angle θ shown in Fig. 11.1 The inspection should be performed within 45° when display is shut down. The inspection should be performed within 5° when display is power on.

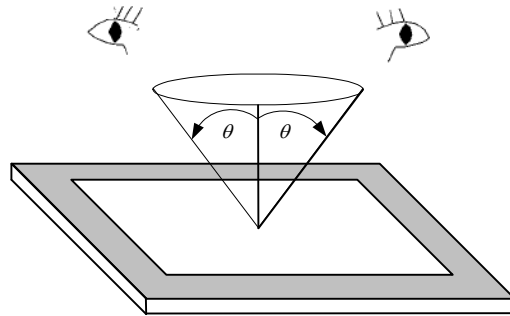

Fig. 11.1

11.1 THE DEFINITION OF LCD ZONE

LCD panel is divided into 3 areas as shown in Fig.11.2 for appearance specification in next section. A zone is the LCD active area (dot area); B zone is the area, which extended 1 mm out from LCD active area; C zone is the area between B zone and metal frame.

In terms of housing design, B zone is the recommended window area customers' housing should be located in.

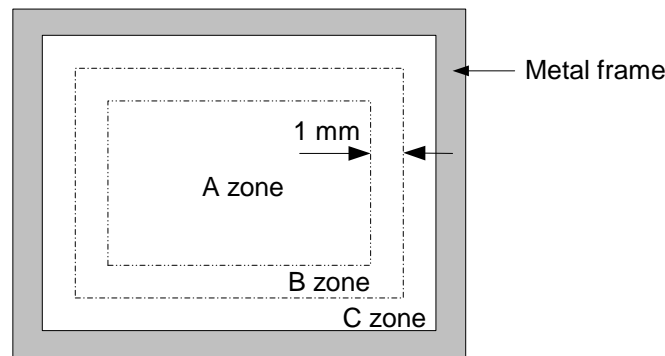

Fig. 11.2

11.2 LCD APPEARANCE SPECIFICATION

The specification as below is defined as the amount of unexpected phenomenon or material in different zones of LCD panel. The definitions of length, width and average diameter using in the table are shown in Fig. 11.3 and Fig. 11.4.

Item	Criteria				Applied zone
	Length (mm)	Width (mm)	Maximum number	Minimum space	
Scratches on polarizer	$L \leq 5$	$W \leq 0.05$	Ignored	-	A,B
	$L \leq 5$	$0.05 < W \leq 0.1$	5	-	
	$5 < L$	$0.1 < W$	0	-	
	Serious one is not allowed				
Wrinkles in polarizer	Serious one is not allowed				A
Bubbles or Dater on polarizer	Average diameter (mm)		Maximum number		A
	$D \leq 0.2$		Ignored		
	$0.2 < D \leq 0.3$		5		
	$0.3 < D$		0		
1) Stains 2) Foreign Materials 3) Dark Spot	Filamentous (Line shape)				A, B
	Length (mm)	Width (mm)	Maximum number		
	$L \leq 5$	$W \leq 0.05$	Ignored		
	$L \leq 5$	$0.05 < W \leq 0.1$	3		
	$5 < L$	$0.1 < W$	0		
	Round (Dot shape)				A, B
	Average diameter (mm)		Maximum number	Minimum Space	
	$D \leq 0.2$		Ignored	-	
	$0.2 < D \leq 0.5$		3	-	
	$0.5 < D$		0	-	
Dot-Defect (Note 1)			Type	Maximum number	A
	Bright dot-defect	1 dot		2	
		2 adjacent dot		1	
		3 adjacent dot or above		Not allowed	
	Dark dot-defect	1 dot		3	
		2 adjacent dot		1	
		3 adjacent dot or above		Not allowed	
In total				5	

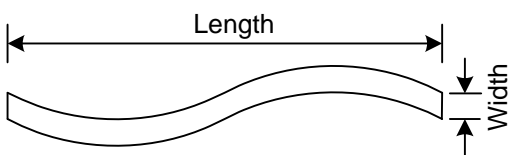
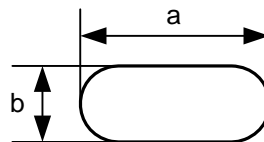

Fig. 11.3



$$\text{Average diameter} = \frac{a + b}{2}$$

Fig. 11.4

Note 1: The definitions of dot defect are as below:

- The defect area of the dot must be bigger than half of a dot.
- For bright dot-defect, showing black pattern, the dot's brightness must be over 30% brighter than others.
- For dark dot-defect, showing red,green,blue pattern, the dot's brightness must be under 70% darker than others.
- The definition of 1-dot-defect is the defect-dot, which is isolated and no adjacent defect-dot.
- The definition of adjacent dot is shown as Fig. 11.5.

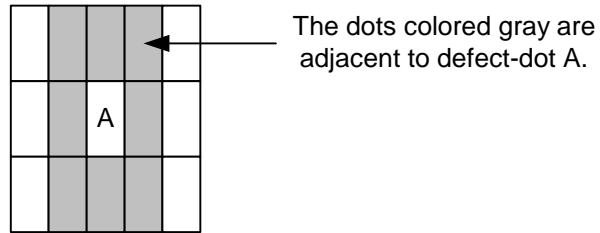

Fig. 11.5

12. PRECAUTIONS

12.1 PRECAUTIONS of ESD

- 1) Before handling the display, please ensure your body has been connected to ground to avoid any damages by ESD. Also, do not touch display's interface directly when assembling.
- 2) Please remove the protection film very slowly before turning on the display to avoid generating ESD.

12.2 PRECAUTIONS of HANDLING

- 1) In order to keep the appearance of display in good condition, please do not rub any surfaces of the displays by using sharp tools harder than 3H, especially touch panel, metal frame and polarizer.
- 2) Please do not stack the displays as this may damage the surface. In order to avoid any injuries, please avoid touching the edge of the glass or metal frame and wore gloves during handling.
- 3) Touching the polarizer or terminal pins with bare hand should be avoided to prevent staining and poor electrical contact.
- 4) Do not use any harmful chemicals such as acetone, toluene, and isopropyl alcohol to clean display's surfaces.
- 5) Please use soft cloth or absorbent cotton with ethanol to clean the display by gently wiping. Moreover, when wiping the display, please wipe it by horizontal or vertical direction instead of circling to prevent leaving scars on the display's surface, especially polarizer.
- 6) Please wipe any unknown liquids immediately such as saliva, water or dew on the display to avoid color fading or any permanent damages.
- 7) Maximum pressure to the surface of the display must be less than 1.96×10^4 Pa. If the area of applied pressure is less than 1 cm^2 , the maximum pressure must be less than 1.96N.

12.3 PRECAUTIONS OF OPERATING

- 1) Please input signals and voltages to the displays according to the values defined in the section of electrical characteristics to obtain the best performance. Any voltages over than absolute maximum rating will cause permanent damages to this display. Also, any timing of the signals out of this specification would cause unexpected performance.
- 2) When the display is operating at significant low temperature, the response time will be slower than it at 25°C . In high temperature, the color will be slightly dark and blue compared to original pattern. However, these are temperature-related phenomenon of LCD and it will not cause permanent damages to the display when used within the operating temperature.
- 3) The use of screen saver or sleep mode is recommended when static images are likely for long periods of time. This is to avoid the possibility of image sticking.
- 4) Spike noise can cause malfunction of the circuit. The recommended limitation of spike noise is no bigger than $\pm 100 \text{ mV}$.

KAOHSIUNG HITACHI ELECTRONICS CO.,LTD.	DATE	Nov.29,'10	Sh. No.	7B64PS 2712-TX11D04VM2AAA-2	PAGE	12-1/2
---	------	------------	------------	-----------------------------	------	--------

12.4 PRECAUTIONS of STORAGE

If the displays are going to be stored for years, please be aware the following notices.

- 1) Please store the displays in a dark room to avoid any damages from sunlight and other sources of UV light.
- 2) The recommended long term storage temperature is between 10 C° ~35 C° and 55%~75% humidity to avoid causing bubbles between polarizer and LCD glasses, and polarizer peeling from LCD glasses.
- 3) It would be better to keep the displays in the container, which is shipped from Hitachi, and do not unpack it.
- 4) Please do not stick any labels on the display surface for a long time, especially on the polarizer.

13 DESIGNATION OF LOT MARK

1) The lot mark is showing in Fig.13.1. First 4 digits are used to represent production lot and the last 6 digits are the serial number.

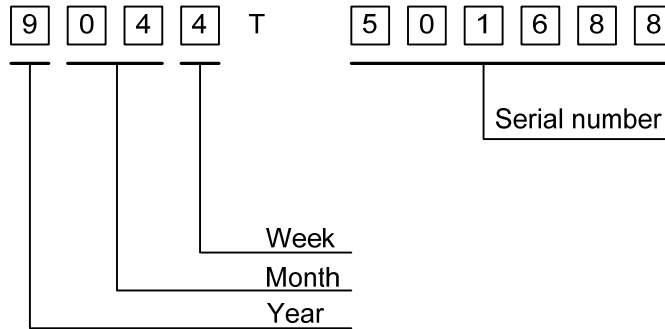

Fig. 13.1

2) The tables as below are showing what the first 4 digits of lot mark are shorted for.

Year	Lot Mark
2010	0
2011	1
2012	2
2013	3
2014	4

Month	Lot Mark	Month	Lot Mark
Jan.	01	Jul.	07
Feb.	02	Aug.	08
Mar.	03	Sep.	09
Apr.	04	Oct.	10
May	05	Nov.	11
Jun.	06	Dec.	12

Week	Lot Mark
1~7 days	1
8~14 days	2
15~21 days	3
22~28 days	4
29~31 days	5

3) Except letters I and O, revision number will be shown on lot mark and following letters A to Z.

4) The location of the lot mark is on the back of the display shown in Fig. 13.2.

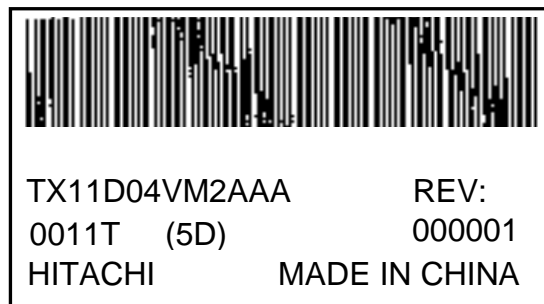

Fig. 13.2