

M / S (HEU)

DATE: 7.Jul.2009
Hitachi Consumer Electronics Co., Ltd.
New Light Source Business
Promotion Center
Ome Manufacturing Operation
Hitachi Lighting,Ltd
16-2,shinmachi 6-chome,Ome-Shi
Tokyo 198-8611,JAPAN
TEL.0428-31-1204
FAX.0428-31-1224

**CUSTOMER'S ACCEPTANCE
SPECIFICATIONS**
(Backlight Inverters for cold cathode
fluorescent lamp)

TYPE: INVC 828

CONTENTS

| No | ITEM | Page |
|----|----------------------------|------|
| | Cover | 1 |
| | Record of Revision | 2 |
| 1 | Scope | 3 |
| 2 | General Specifications | 3 |
| 3 | Electrical Characteristics | 3-5 |
| 4 | Reliability | 5 |
| 5 | Structures | 6 |
| 6 | Structures and Dimensions | 7 |
| 7 | Precautions in Design | 8-9 |

Accepted by

Proposed by

J. Ando

1. Scope

- 1.1 This specification shall apply to inverter INVC828 to operate a cold cathode fluorescent lamp in the liquid-crystal display (LCD).
- 1.2 This inverter INVC828 is designed and adjusted for LMG74 * 0PLFC , LMG74 * 1PLBC, LMG532 * XUFC , SP12N002 and SP14N00 * LCD-module. (Hitachi Displays type name)

2. General Specifications

General specifications and condition for use are shown below.

| Item | Specification |
|---|---------------------|
| Cooling condition | Free air flow |
| Weight | 7.3g typ. |
| Ambient temperature (direct ambient air of Inverter board) | Operating -10~60deg |
| | Stock -20~85deg |
| Humidity | 85 % RH.max. |
| Corrosive gasses | Not acceptable |

3. Electrical Characteristics

3.1. Maximum rating

| Items | Min. | Typ. | Max. | unit | Remarks |
|---------------|------|------|------|------|---------|
| Input voltage | --- | --- | 18.0 | V | |

3.2. Operating Characteristics

LMD7420PLFC-X

AT=25deg.C

| Item | Min | Typ | Max | Unit | Remarks |
|---------------------|-----|--------|------|------|----------|
| Input voltage | 7.0 | 12.0 | 17.0 | V | |
| Input current | 130 | 165 | 200 | mA | at 12.0V |
| Rush current | --- | --- | 20 | A | at 12.0V |
| Lamp current | 4.5 | 5.0 | 5.5 | mA | at 12.0V |
| Lamp power | --- | 1.50 | --- | W | at 12.0V |
| Main frequency | 50 | 60 | 70 | kHz | at 12.0V |
| Dimming range | --- | 100~50 | --- | % | |
| Open output voltage | --- | 1400 | --- | Vrms | at 12.0V |

- (1) All characteristics are measured by our certain test equipment. The measurement of condition should be stable lighting (more than 30 minutes after startup :at 25+/-1deg.C and no breath of wind) (The measurement of input rush current is exception) .
- (2) The electrical characteristics are measured as we show on measurement diagram Fig.1. Vin=12.0V.
- (3) As we show on measurement diagram Fig.1, the test equipment shall be V1:DC Volt meter (Class0.5) A1:DC Current meter(Class0.5) A2:AC Current meter type2016(Y.E.W) or FLUKE45(FLUKE) Vin:PW18-2TP(Kenwood) .
- (4) The line length of between the lamp and CN2(high voltage)is less than 150mm.

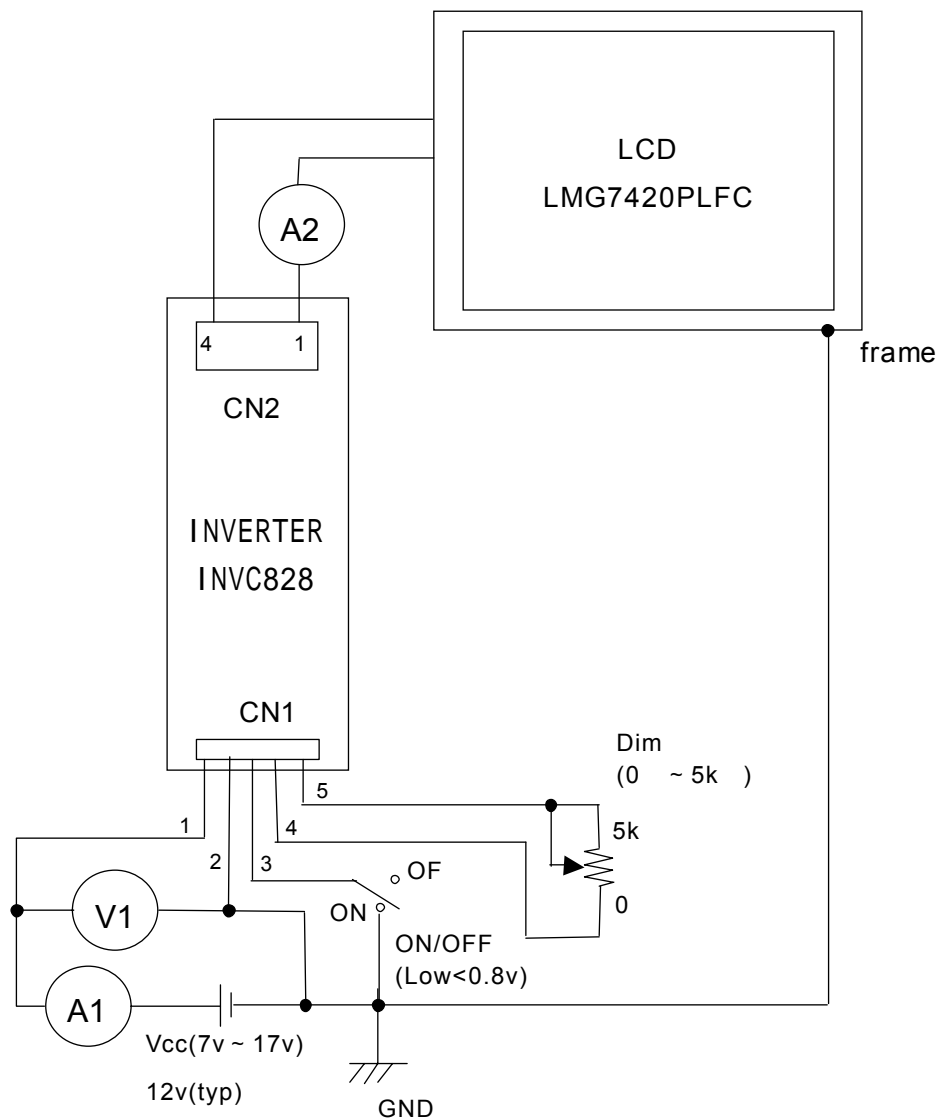
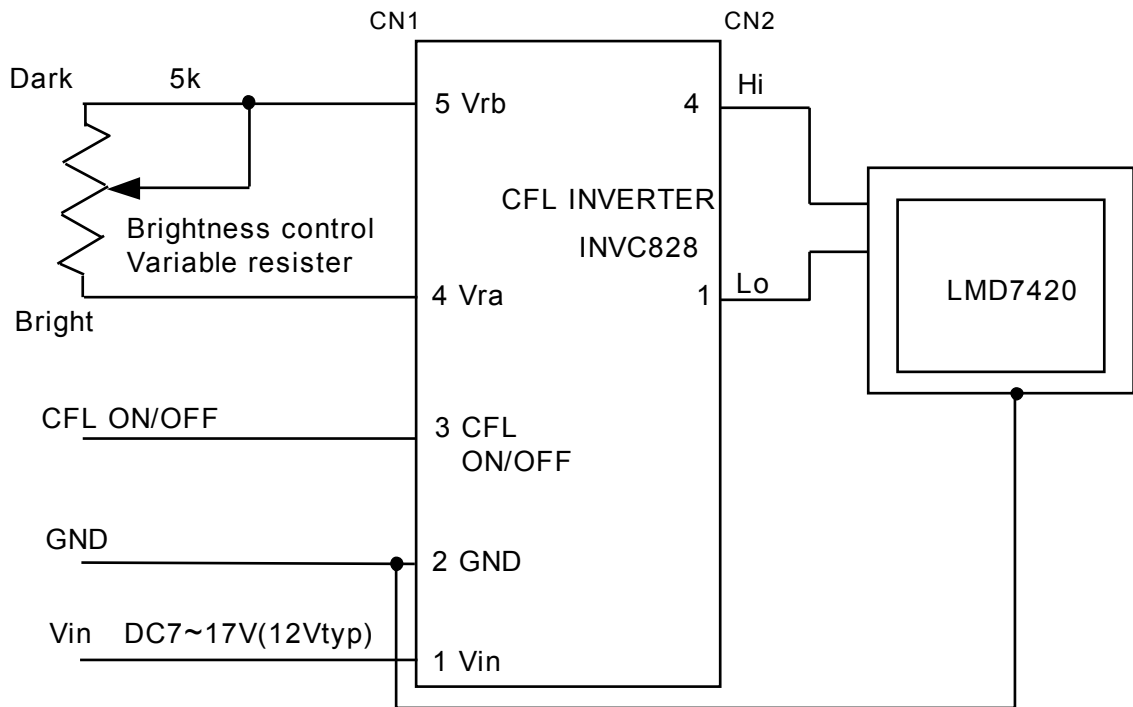

Fig.1 Wiring

3.3. Wiring Diagram



Note : Controlled by external open-collector circuit.

Fig.2 Wiring Diagram

4. Reliability

| Item | Test condition |
|------------------------------|--|
| Low temp. operate | 0deg.C, 12.0V, 100%output, 500Hrs |
| High temp. operate | 60deg.C, 12.0V, 100%output, 500Hrs |
| Low temp. stock | -20deg.C, 500Hrs |
| High temp. stock | 85deg.C, 500Hrs |
| High temp. and high humidity | 50deg.C, 85% 12.0V, 100%output, 500Hrs |
| Cyclic temp. operate | 0deg.C - 25deg.C - 50deg.C 1Hr each 12.0V, 100%output, 50cycles |
| Thermal shock | -20deg.C - 70deg.C, 0.5Hrs each 100cycles |
| Vibration | 3G, 30~200Hz, 0.5Hrs,xyz-axis |
| Impact test | 50G,xyz-axis |

5.Structures

5.1 Dimensions

Reference to drawing P.7

5.2 Interface specification

Input connector CN1:53261-0571(molex) or equivalent

| Pin No. | Symbol | Comment |
|---------|---------------|---------------------------------------|
| 1 | Vin | DC7~17V |
| 2 | GND | |
| 3 | CFL ON/OFF | ON: "L"Vol<0.8V,Iol=2mA OFF:"open" |
| 4 | Vra | LOWER potential |
| 5 | Vrb | UPPER potential |

Note : Pin No.3 is connected with Vin by pull-up resistor 145kΩ.

Output connector CN2:IL-G-4P-S3L2-SA(JAE)

| Pin No. | Symbol |
|---------|--------|
| 1 | Lo |
| 2 | -- |
| 3 | -- |
| 4 | Hi |

6.Structures and Dimensions

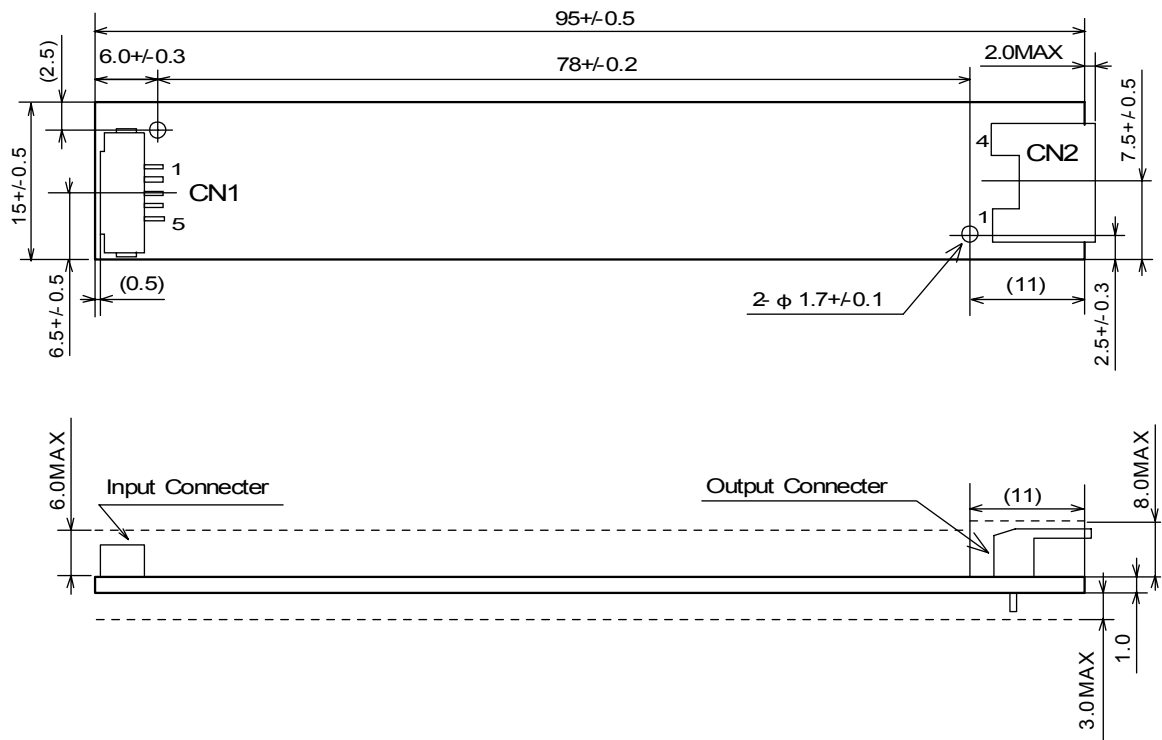

Fig.3 Dimensional Outline

Date code : ex "11E9"

7. Precautions in Design

7.1 Please turn off the power supply of the inverter before the output connector (CN2) is put in or put off. Because the voltage of the output connector is very high.

7.2 The high-voltage wiring of lamps may affect the characteristics of this product even in the presence of a slight stray capacity of 1 to few pF. So, please check whatever the below points have fully considered.

(1) Please use UL1330 equivalents as inverter output leads and keep length within 150mm.

(2) Please keep the length of wiring as short as possible and at the same time avoid binding high-voltage leads together and fitting high-voltage leads near the shield.

(3) Consider the electric potential of the parts adjacent to a wire because it greatly affects the electric characteristics and startup characteristics.

7.3 In the case of putting in and putting off the connector (CN1), please switch off the power supply of the inverter. If the power supply is operating, it will be possible that the inverter breaks down.

7.4 Please pay attention when using the inverter. Because the transformer in the inverter is weak to impact.

7.5 If it was exposed to thermal shock (out of order), it may have a crack itself.

7.6 Please do not give it any changes, such as reworking it, applying and hardening with adhesives, molding with resin, fixing with tape.

7.7 Please make a tight connection of the output and input connector. (If the inverter's connector contact was imperfect, the components of the inverter have high temperature and break down.)

7.8 Pay attention as printed circuit board is bent, and not adding excessive pressure when printed circuit board is built in. (Deterioration and the damage of component are caused, and movements of inverter are out of order.)