

Basics of LCD Technologies

Introduction

Flat panel displays are present in every day life. You can find them in laptops, watches, shavers, washing machines, copy machines and car audio systems. Most flat panel displays are “liquid crystal displays” or abbreviated “LCDs”. This Application Note gives a short introduction to LCDs and associated basic principles.

Contents

INTRODUCTION	1
CONTENTS	1
1 CHEMICAL BASICS	2
2 IMPORTANT CHARACTERISTICS OF LIQUID CRYSTALS	2
3 “NEMATIC” CELLS	2
4 “SWITCHING” OF LIGHT	2
5 VIEWING MODES AND LIGHT SOURCES	3
6 LCD TECHNOLOGIES BY HITACHI	4

Index of Figures

Figure 1: Basic principle of a TN-Cell	3
--	---

1 Chemical basics

Standard materials (Iron, Silicon, Water, etc.) have three phases: solid, fluid and gas. When solid, most materials have a crystalline structure.

Liquid crystal materials have four phases: The three normal ones and the liquid crystal phase when going from solid to fluid. This phase is typically between a temperature of -100°C and $+100^{\circ}\text{C}$.

In the liquid crystal phase the material has the ability of orientate like crystals and the viscosity of a fluid. Furthermore, the liquid crystal phase can have its own separate states “smectic” and “nematic”.

2 Important characteristics of Liquid Crystals

- Liquid Crystals are very sensitive to constant electric fields. Only AC-voltages should be applied as DC voltages can cause an electrochemical reaction which destroys the liquid crystals irreversibly.
- They do not emit light only refract it. Thus, an LCD always needs a light source (See #4 and #5 for details)
- They change their behaviours with temperature. In a very cold or hot environment a LCD may not work correctly. This is a reversible effect. Some displays need temperature compensation circuits to automatically adjust the applied LC voltage.

3 “Nematic” Cells

Most LCDs use “nematic” state crystals in “Twisted Nematic” (TN) or “Super Twisted Nematic” (STN) technologies. Some special and niche applications use other liquid crystal states or technologies.

4 “Switching” of Light

A LCD cell is produced using a thin layer of LC material sandwiched between two sheets of glass. An alignment layer on the internal surface of each sheet aligns the crystal cells. A polarizer is used on the top and bottom of the cell to align the light source (see Figure 1).

When there is no voltage across the cell, the crystals are in a static mode: they orientate themselves to the alignment layers at the top and bottom.

The light passes through the first polarizer, is rotated by the LC fluid and blocked at the second polarizer. In a TN-cell the light is twisted or rotated by 90° and in an STN-cell by 180° - 270° . Additionally there are some effects in an STN-cell making them better in multiplex driving than TN-cells but the principles are the same.

When the voltage is “on”, the liquid crystals are orientated by the electric field. The light is not rotated by the liquid crystals any more and can pass through.

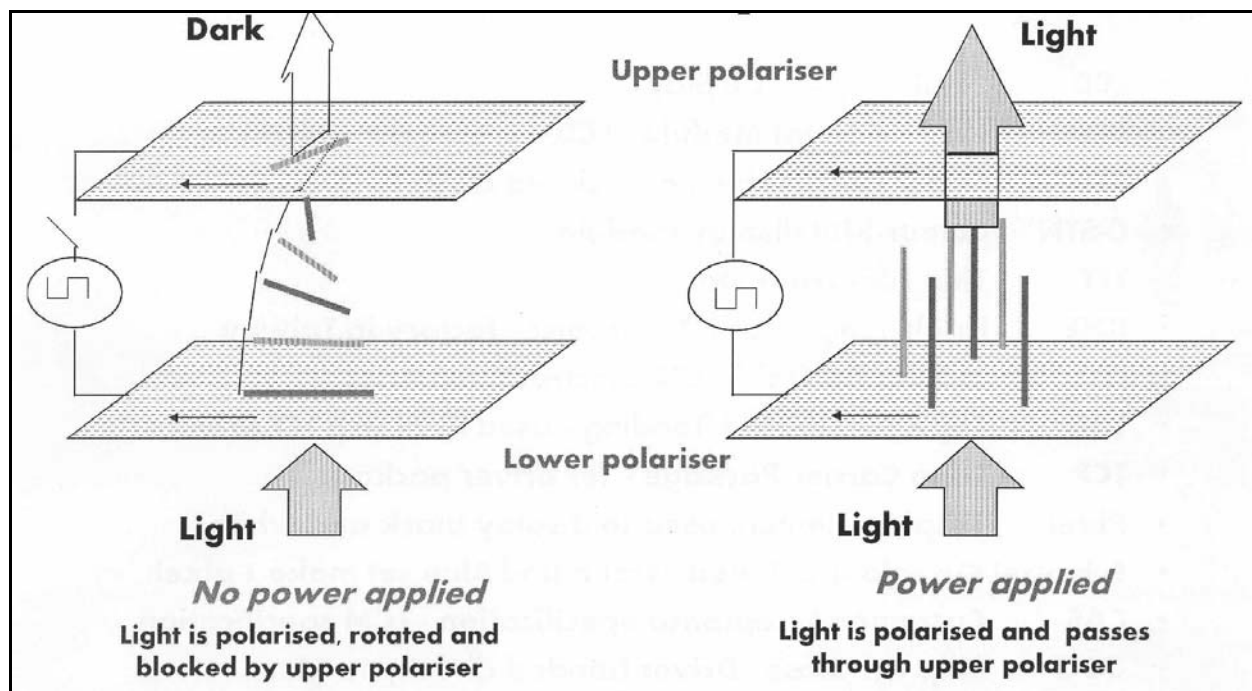

Figure 1: Basic principle of a TN-Cell.

Note: This principle applies to positive-type LCDs (black information on bright, e.g. grey or white background) which is the most popular type. For the negative type, either the top or the bottom polarizer is rotated by 90°. (then “on”=dark, “off”=bright)

Colour displays have additional colour filters to filter the light. White light is a combination of three colours: Red, green and blue. To display a red pixel, then the green and blue element of light must be filtered.

5 Viewing modes and Light Sources

There are three viewing modes: “Reflective”, “Transmissive” and “Transflective”.

In reflective mode, ambient light is used as a light source: sunlight for example is reflected by a layer behind the liquid crystal layer. This technology can be found in watches or calculators. These displays have the lowest power consumption but however, if there is no ambient light (for example at night) nothing can be seen.

In transmissive mode there is a light source behind the LCD cell. Ambient light is undesirable because it decreases the contrast and brightness of the LCD.

The third mode is transflective. A combination of ambient light and a light source behind the display is used. Typically the backlight to the display can be switched off. Many PDAs and mobile phones use this transflective mode displays.

Typical backlighting technologies utilise cold cathode fluorescent lamps (CCFL), electro luminescent foil (EL) or light emitting diodes (LEDs).

Please find more information about backlighting technologies in Application Note AN-007.

6 LCD Technologies by Hitachi

Blue Mode STN – Basic operation mode of LCDs. The display image is a blue on white background.

FSTN (Film STN) – An additional linearization film added to a basic STN LCD to give black and white characteristics. This leads to black pixels on a white background.

CSTN (colour STN) – Colour filters are used to create up to 65,000 colours. Each pixel is split in red/green/blue sub-pixels.

Graphics Module – Capable of showing bitmap graphics and characters.

Cautions

Keep safety first in your circuit designs!

- Hitachi Europe Ltd. puts the maximum effort into making display products better and more reliable, but there is always the possibility that trouble may occur with them. Trouble with display products may lead to personal injury, fire or property damage.
Remember to give due consideration to safety when making your circuit designs, with appropriate measures such as (i) placement of substitutive, auxiliary circuits, (ii) use of nonflammable material or (iii) prevention against any malfunction or mishap.

Notes regarding these materials

- These materials are intended as a reference to assist customers in the selection of the Hitachi Europe Ltd. display products best suited to the customer's application; they do not convey any license under any intellectual property rights, or any other rights, belonging to Hitachi Europe Ltd. or a third party.
- Hitachi Europe Ltd. assumes no responsibility for any damage, or infringement of any third-party's rights, originating in the use of any product data, diagrams, charts, programs, algorithms, or circuit application examples contained in these materials.
- All information contained in these materials, including product data, diagrams, charts, programs and algorithms represents information on products at the time of publication of these materials, and are subject to change by Hitachi Europe Ltd. without notice due to product improvements or other reasons. It is therefore recommended that customers contact Hitachi Europe Ltd. or an authorized Hitachi Europe Ltd. product distributor for the latest product information before purchasing a product listed herein.
The information described here may contain technical inaccuracies or typographical errors.
Hitachi Europe Ltd. assumes no responsibility for any damage, liability, or other loss rising from these inaccuracies or errors.
When using any or all of the information contained in these materials, including product data, diagrams, charts, programs, and algorithms, please be sure to evaluate all information as a total system before making a final decision on the applicability of the information and products. Hitachi Europe Ltd. assumes no responsibility for any damage, liability or other loss resulting from the information contained herein.
- Hitachi Europe Ltd. display products are not designed or manufactured for use in a device or system that is used under circumstances in which human life is potentially at stake. Please contact Hitachi Europe Ltd. or an authorized Hitachi Europe Ltd. product distributor when considering the use of a product contained herein for any specific purposes, such as apparatus or systems for transportation, vehicular, medical, aerospace, nuclear, or undersea repeater use.
- The prior written approval of Hitachi Europe Ltd. is necessary to reprint or reproduce in whole or in part these materials.
- Please contact Hitachi Europe Ltd. for further details on these materials or the products contained therein.

Copyright © Hitachi Europe Ltd. All rights reserved